

ZG20/21

Intermediate Gear

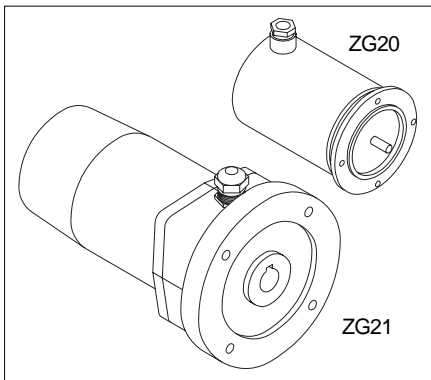

ENGLISH

1. Warranty information

- In order to carry out installation correctly, we strongly recommend this document is read very carefully. This will ensure your own safety and the operating reliability of the device.
- Your device has been quality controlled, tested and is ready for use. Please observe all warnings and information which are marked either directly on the device or specified in this document.
- Warranty can only be claimed for components supplied by SIKO GmbH. If the system is used together with other products, the warranty for the complete system is invalid.
- The guarantee period is 6 months starting with the date of invoice.
- Repairs should be carried out only at our works. If any information is missing or unclear, please contact the SIKO sales staff.

2. Identification

Please check the particular type of unit and type number from the identification plate. Type number and the corresponding version are indicated in the delivery documentation.

e.g. ZG20-0023
 _____ version number
 _____ type of unit

3. Summary description

The intermediate gears are of very robust design and compact size.

Max. 3 trip control 3 switching actions.

4. Mounting instructions

Please handle the unit carefully as it is a high-precision device.

Especially do not:

- disassemble or open the unit (unless stipulated in this brochure).
- link unit's shaft with rigid couplings as this would expose the unit's shaft bearing to high forces. For solid shaft units we recommend the use of SIKO flexible shaft coupling type AK18.
- knock the housing and the shaft.
- machine (bore, mill ...) flange or shaft. This could lead to severe damage inside the unit.
- exceed the values for the maximum axial and radial shaft load.
- mount the unit incorrectly.

Otherwise manufacturer's warranty will be invalidated!

NEVER ...

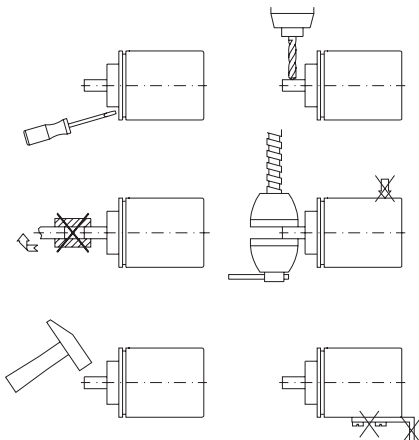

5. Installation

For mounting, the degree of protection specified must be observed. If necessary, protect the unit against environmental influences such as sprayed water, dust, knocks, extreme temperatures.

Mounting of the unit

- Use the frontal bores to fix the unit. Mount unit without force.
- Forces must not be transmitted via the housing, but only via the shaft.
- Do not exceed the values for the maximum axial and radial shaft load.
- Ensure accurate shaft alignment. If shaft and flange are not correctly aligned, strain on the bearings will result, which will overheat and be irreparably damaged.

6. Electrical connection

- **Switch power off before any plug is inserted or removed !!**
- Wiring must only be carried out with power off.
- Provide stranded wires with ferrules.
- Check all lines and connections before switching on the equipment.

Interference and distortion

All connections are protected against the effects of interference. **The location should be selected to ensure that no capacitive or inductive interferences can affect the encoder or the connection lines!** Suitable wiring layout and choice of cable can minimise the effects of interference (eg. interference caused by switching power supplies, motors, cyclic controls and contactors).

Necessary measures:

- Wire cross section is to be at least 0,14 mm², max. 0,5 mm².

6.1 How to open and close the device

For opening ZG20:

- Remove the grub screws in the cap for opening the unit.

For opening ZG21:

- To open the unit, remove fastening screws on the cap.
- Ensure that the sealing is not damaged or lost.

For closing ZG20:

- Put the cap onto the flange.
- Tighten the grub screws.

For closing ZG21:

To easily close the unit and to avoid cable damage, we recommend securing the inner

strands with an adhesive tape. The adhesive tape should be insensitive to temperature and ageing.

- Put the cap onto the flange. Washer must be properly fitted into the nut.
- Tighten the fastening screws.

6.2 Cable connection

- Prepare wire accord. to fig. 1
- Open the device (see chapter 6.1) and unscrew the PG-screws.

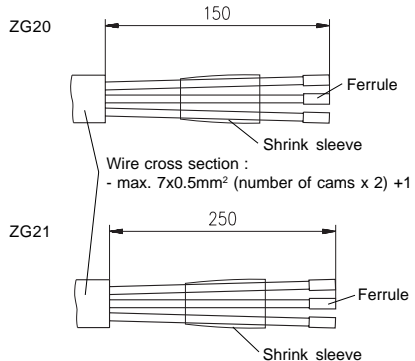

Fig. 1 : Cable preparation

With PG9 :

- Push nut-gasket (1), washer (2) (inner- \varnothing > washer's inner- \varnothing (3)) and washer (3) onto the cable.
- Push strands through the screw hole (4). Insert parts (3) and (2) into the screw hole (4).
- Fix nut (1) and then fix the complete PG-screw to the casing.

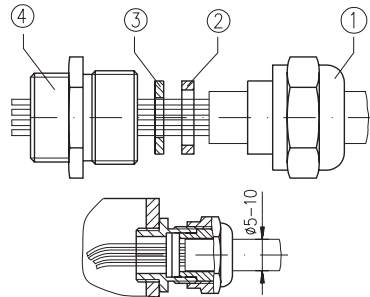

Fig. 2 : Cable connection PG9

- Connect strands to the clip terminals (fig. 3).
- Close the geared potentiometer (see chapter 6.1).

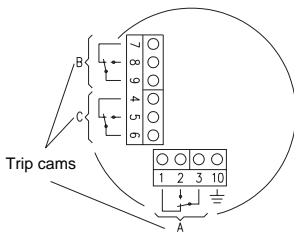

Fig. 3 : Pin connection

7. Adjustment

7.1 Adjustment of the trip cams

Ex works the trip cams are **not** fixed radially to the shaft. Adjustment is made after installation.



Important information!

Do not touch the roller levers during trip cam adjustment: damage from bending may result.

- Bring the turnable trip cams (A, B, C) into a position which is favorable for fine adjustment: grub screw (1) and screw (2) must be easily accessible.
- Fix the grub screws (1) to prevent straining of the trip cams.
- The setting screw (2) is used for precise setting of the trip cam; use a screw driver size 3 (see fig. 4).

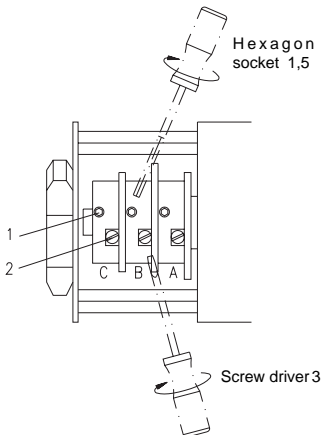

Fig. 5 : Trip cam adjustment

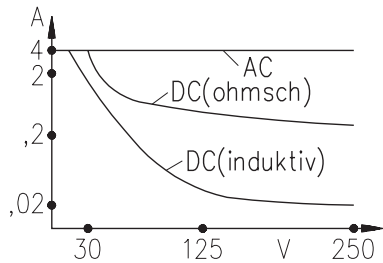

Fig. 5 : Nomogram: Load rating cam switches

8. Starting

Please ensure that the instructions given in chapter 5 and 6 regarding mechanical and electrical connection are followed. This will ensure correct installation and the operating reliability of the device.

Before starting check again:

- correct polarity of the supply voltage
- correct cable connection
- correct mounting of the device

SIKO GmbH
DR.-ING. G. WANDRES

Postanschrift / Postal address:
Postfach 1106
D-79195 Kirchzarten

Werk / Factory:
Weihermattenweg 2
D-79256 Buchenbach

Telefon / Phone 0 76 61 / 3 94 - 0
Telefax / Fax 0 76 61 / 3 94 - 388
Internet www.siko.de

