

# Incremental encoder IV58L

Solid shaft

IV58L - the economical one! An alternative for many applications in standard design.



**Features:**

- resolution max. 512 pulses/revolution
- standard 58 mm flange
- economical design

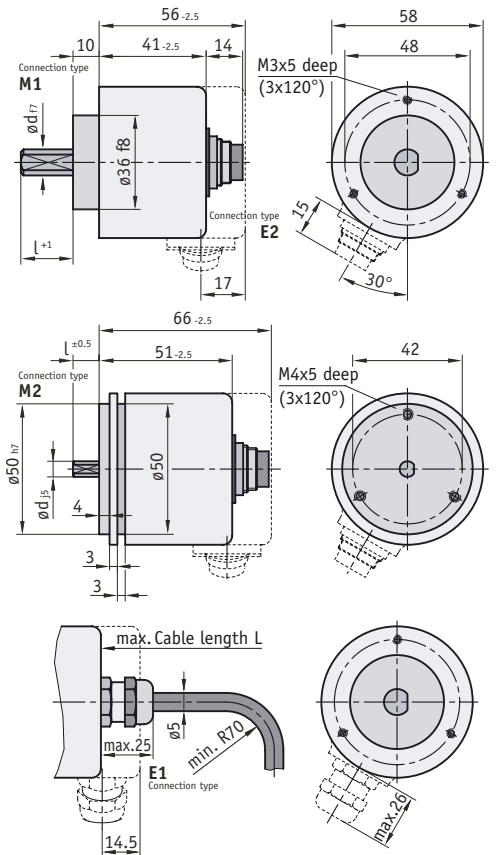

Feature	Order text	Technical data	Additional information
Output signals	AXX	A ABX, ABO	
	...		
Pulses/revolution	...	B 10, 20, 25, 30, 36, 50, 60, 64, 96, 100, 125, 200, 250, 300, 360, 400, 500, 512	
Connection type	E1	C stripped cable ends connector	
	E2		mating connector available as an accessory, art. no. 76454
Position of electrical connection	A	D axial radial	
	R		
Cable length L [m]	2.0	E 1.0, 2.0, 3.0, 5.0, 8.0, 10.0 without cable (only for E2)	
	OK		
Mounting type	M1	F clamping flange servo flange	
	M2		
Shaft diam. x length [mm]	6 x 10	G d x l	
	10 x 20		
<b>Mechanical data</b>			
Speed		max. 6000 min <sup>-1</sup>	
Rotor moment of inertia		approx. 0.6 x 10 <sup>-6</sup> kgm <sup>2</sup>	
Starting torque		< 0.01 Nm	
Load capacity of shaft		radial 40N, axial 20N	
Weight		approx. 0.4 kg	
Type of protection		IP 64	according to EN 60 529
Working temperature		0 °C ... +50 °C	
Shaft		stainless steel	
Cable sheath		PVC	
Shock resistance		1000 m/s <sup>2</sup> , 6 ms	according to DIN-IEC 68-2-27
Vibration resistance		100 m/s <sup>2</sup> , 10 ... 2000 Hz	according to DIN-IEC 68-2-6
<b>Electrical data</b>			
Output circuit		PP- push-pull	
Operating voltage		10 ... 30 V DC	
Power cons. without load (typ.)		80 mA	
Permitted load/channel (max.)		± 30 mA	
Pulse frequency (max.)		20 kHz	
Signal level high (min.)		UB - 2.5 V	
Signal level low (max.)		1.5 V	
Rise time t <sub>r</sub> (max.)		1 µs	
Fall time t <sub>f</sub> (max.)		1 µs	
Short-circuit proof outputs		yes, polarity protection on UB	
<b>Other data</b>			
Test mark		CE	

Your order data:  -  -  -  -  -  -  -