

Incremental encoder IV58

Solid shaft

IV58 - the standard encoder! Universal and variable in many points. The ideal incremental encoder with solid shaft for all applications.



Features:

- resolution max. 36000 pulses/revolution
- various working temperature ranges selectable
- high load capacity of shaft
- standard 58 mm flange
- high type of protection: IP66

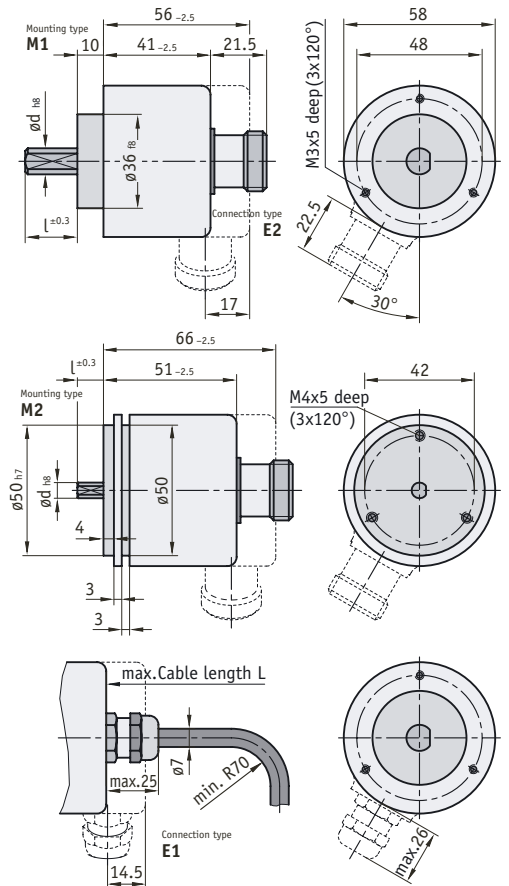

Feature	Order text	Technical data	Additional information		
Pulses/revolution	...	A	10, 20, 25, 30, 50, 60, 100, 120, 125, 127, 150, 180, 200, 216, 240, 250, 254, 256, 300, 314, 360, 375, 400, 500, 512, 600, 625, 720, 745, 750, 762, 800, 900, 927, 1000, 1024, 1250, 1270, 1400, 1500, 1800, 2000, 2048, 2250, 2400, 2500, 3000, 3600, 4000, 4096, 5000, 9000, 10000, 18000, 25000, 36000		
	Connection type	E1	B	stripped cable ends	
		E2		connector	mating connector available as an accessory, article no. 81273
	Position of electrical connection	A	C	axial	
		R		radial	
	Cable length L [m]	2.0	D	1.0, 2.0, 3.0, 5.0, 8.0, 10.0	
		OK		without cable (only E2)	
Mounting type	M1	E	clamping flange		
	M2		servo flange		
Output circuit	PP	F	push-pull		
	OP		push-pull with additional inverted signals		
	LD		RS422, 5 V DC operating voltage		
	LD24		RS422, 24 V DC operating voltage		
Shaft diam. x length [mm]	6 x 10	G	d x l		
	10 x 20				
Type of protection	65	H	IP65	according to EN 60 529	
	66		IP66	according to EN 60 529	
Working temperature	T1	I	-20 °C ... +70 °C	PVC cable sheath	
	T2		-20 °C ... +85 °C	PUR cable sheath	
	T3		-20 °C ... +105 °C	TPE cable sheath	
Pulse frequency [in kHz]	300	K	600, 800		
Mechanical data					
Speed			max. 12000 min ⁻¹		
Rotor moment of inertia			approx. 1.8 x 10 ⁻⁶ kgm ²		
Starting torque			< 0.01 Nm		
Load capacity of shaft			radial 80N, axial 40N		
Weight			approx. 0.4 kg		
Shaft			stainless steel		
Shock resistance			1000 m/s ² , 6 ms	according to DIN-IEC 68-2-27	
Vibration resistance			100 m/s ² , 10 ... 2000 Hz	according to DIN-IEC 68-2-6	
Electrical data					
Output signals		PP	OP	LD	LD24
Operating voltage		AB0	AB0	AB0	AB0
Power cons. without load (typ.)		10 ... 30 V DC	10 ... 30 V DC	5 V DC ±5%	10 ... 30 V DC
without inverting max. 300 kHz		55 mA	80 mA	70 mA	70 mA
with inverting max. 300 kHz		125 mA			
without inverting max. 600 kHz			150 mA	100 mA	100 mA
with inverting max. 600 kHz		90 mA	115 mA		
without inverting max. 800 kHz		135 mA			
with inverting max. 800 kHz			160 mA		
Power cons. without load (typ.)				70 mA	70 mA
With inverting max. 800 kHz				100 mA	100 mA
Permitted load/channel (max.)		± 30 mA	± 30 mA	± 20 mA	± 20 mA
Signal level high (min.)		UB - 3 V	UB - 3 V	2.5 V	2.5 V
Signal level low (max.)		2.5 V	2.5 V	0.5 V	0.5 V
Rise time t _r (max.)		1 µs	1 µs	200 ns	200 ns
Fall time t _f (max.)		1 µs	1 µs	200 ns	200 ns
Short-circuit proof outputs		yes	yes	yes, only 1 channel *	yes, only 1 channel **
Polarity protection on UB		yes	yes	no	yes
Other data					
Test mark		CE			

* Short circuit towards other channels, 0V or +UB permitted

** Short circuit towards other channels, or 0V permitted

Your order data: - - - - - - - - - -