

# Incremental encoder IH58

Hollow shaft

IH58 - the universal one! - As a result of its compact design, it makes possible not only quick but also universal mounting.



**Features:**

- resolution max. 5000 pulses/revolution
- easy installation
- high type of protection: IP66
- through hollow shaft up to diam. 15 mm
- compact design

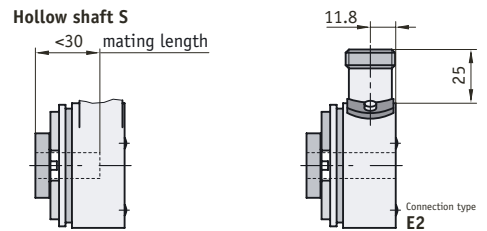
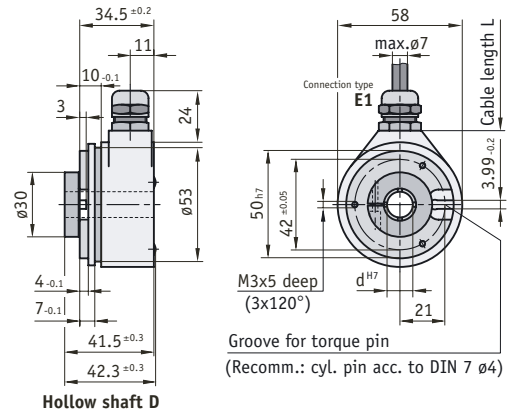

Feature	Order text	Technical data	Additional information		
Pulses/revolution	...	A	10, 20, 25, 30, 50, 60, 100, 120, 125, 127,		
			150, 180, 200, 216, 240, 250, 254, 256,		
			300, 314, 360, 375, 400, 500, 512, 600,		
			625, 720, 745, 750, 762, 800, 900, 927,		
			1000, 1024, 1250, 1270, 1400, 1500, 1800,		
			2000, 2048, 2250, 2400, 2500, 3000, 3600,		
			4000, 4096, 5000		
		others on request			
Connection type	E1	B	stripped cable ends		
	E2		connector	mating connector available as an accessory, article no. 81273	
Cable length L [m]	2.0	C	1.0, 2.0, 3.0, 5.0, 8.0, 10.0		
	OK		without cable (only E2)		
Output circuit	PP	D	push-pull		
	OP		push-pull with additional inverted signals		
	LD		RS422, 5 V DC operating voltage		
	LD24		RS422, 24 V DC operating voltage		
Hollow shaft	D	E	through		
	S		blind hole		
Hollow shaft diam. [mm]	6	F	d		
			8, 10, 12, 14, 15		
Type of protection	66	G	IP66	according to EN 60 529	
	40		IP40	according to EN 60 529	
Working temperature	T1	H	-20 °C ... +70 °C	PVC cable sheath	
	T2		-20 °C ... +85 °C	PVC cable sheath	
	T3		-20 °C ... +105 °C	TPE cable sheath	
	T4		-20 °C ... +80 °C	PVC cable sheath	
	T5		-20 °C ... +90 °C	TPE cable sheath	
<b>Mechanical data</b>					
Speed			IP40 max. 12000 min <sup>-1</sup> , IP66 max. 6000 min <sup>-1</sup>		
Rotor moment of inertia			approx. 6 x 10 <sup>-6</sup> kgm <sup>2</sup>		
Starting torque			IP40 < 0.01 Nm, IP66 < 0.05 Nm		
Weight			approx. 0.4 kg		
Shaft			stainless steel		
Shock resistance			2000 m/s <sup>2</sup> , 6 ms	according to DIN-IEC 68-2-27	
Vibration resistance			100 m/s <sup>2</sup> , 10 ... 2000 Hz	according to DIN-IEC 68-2-6	
<b>Electrical data</b>					
Output signals		PP	OP	LD	LD24
Output signals		ABO	ABO	ABO	ABO
Operating voltage		10 ... 30 V DC	10 ... 30 V DC	5 V DC ±5%	10 ... 30 V DC
Power cons. without load (typ.)		55 mA			
without inverting (max.)		125 mA			
Power cons. without load (typ.)			80 mA	70 mA	70 mA
with inverting (max.)			150 mA	100 mA	100 mA
Permitted load/channel (max.)		± 30 mA	± 30 mA	± 20 mA	± 20 mA
Pulse frequency (max.)		300 kHz	300 kHz	300 kHz	300 kHz
Signal level high (min.)		UB - 3 V	UB - 3 V	2.5 V	2.5 V
Signal level low (max.)		2.5 V	2.5 V	0.5 V	0.5 V
Rise time t <sub>r</sub> (max.)		1 μs	1 μs	200 ns	200 ns
Fall time t <sub>f</sub> (max.)		1 μs	1 μs	200 ns	200 ns
Short-circuit proof outputs		yes	yes	yes, only 1 channel *	yes, only 1 channel **
Polarity protection on UB		yes	yes	no	yes
<b>Other data</b>					
Test mark		CE			

\* Short circuit towards other channels, 0V or +UB permitted

\*\* Short circuit towards other channels, or 0V permitted

Your order data:  -  -  -  -  -  -  -  -