

AS100+MB100

Translation Module

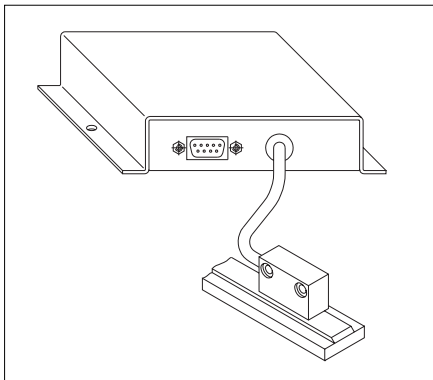

ENGLISH

1. Safety information

In order to carry out installation correctly, we strongly recommend this document is read very carefully. This will ensure your own safety and the operating reliability of the device.

- Your device has been quality controlled, tested and is ready for use. Please respect all warnings and information which are marked either directly on the device or in this document.
- Warranty can only be claimed for components supplied by SIKO GmbH. If the units are used together with other products, the warranty for the complete system is invalid.
- Repairs should be carried out only at our works. If any information is missing or unclear, please contact the SIKO sales staff.

2. Identification

Magnetic strip: identification by printing on the strip.

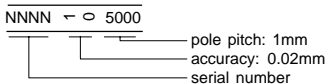

strip width MB100: 5 or 10 mm

Translation module: The particular type of unit and type number can be seen from the identification plate. Type number and the corresponding variations are indicated in the delivery documentation.

e.g. AS100-0023
 └── type number
 └── type of unit

3. Installation

The unit should only be used according to the protection level provided. Protect the system, if necessary, against environmental influences such as sprayed water, dust, knocks, extreme temperatures, solvents.

3.1 Mounting the magnetic strip

The mounting surface / measuring track must be flat. Buckles or bumps will lead to measuring inaccuracies.

For applications which do not allow properly gluing of the magnetic strip, it can be inserted into a **profile rail** (accessory) type **PS** thus forming a compact mounting unit.

For technical reasons the strip should be approx. 25 mm longer than the actual measuring distance.

Attention! To guarantee **optimal adhesion** oil, grease dust etc. must be removed by using cleansing agents which evaporate without leaving residues. Suitable cleansing agents are e.g. ketones (acetone) or alcohols; Messrs. Loctite and 3M can both supply such cleansing liquid. Make sure that the surface to be glued is dry and apply the strip with maximum pressure. Glueing should preferably be undertaken at temperatures between 20 to 30° C and in dry atmosphere.



Advice! When applying long pieces of magnetic strip do not immediately remove the complete protective foil, but rather peel back a short part from the end sufficient to fix the strip. Now align the strip. As the protective strip is then peeled back and out press the tape firmly onto the mounting surface. A wall paper roller wheel could be used to assist in applying pressure onto the magnetic strip when fixing it in position.

Mounting steps (see fig. 1)

- Clean mounting surface (1) carefully.
- Remove protective foil (2) from the adhesive side of the magnetic strip (3).
- Stick down the magnetic strip (4).
- Clean surface of magnetic strip carefully.

- Remove protective foil (6) from adhesive tape on the cover strip (5).
- Fix cover strip (both ends should slightly overlap).
- Also fix cover strip's ends to avoid unintentional peeling.

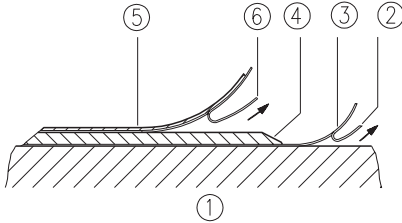

Fig. 1: Mounting of the magnetic strip



Attention! Do not expose the system to magnetic fields. Any direct contact of the magnetic strip with magnetic fields (eg. adhesive magnets or other permanent magnets) is to be avoided. Sensor movements during power loss are not captured by the follower electronics.

Mounting examples

Mounting with chamfered ends (fig. 2) is not recommended unless the strip is installed in a safe and protected place without environmental influences. In less protected mounting places the strip may peel. There we recommend mounting accord. to fig. 3 and 4.

Mounting in a groove (fig. 5) best protects the magnetic strip. The groove should be deep enough to totally embed the magnetic strip.

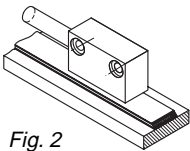

Fig. 2

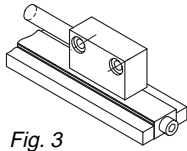

Fig. 3

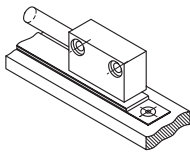

Fig. 4

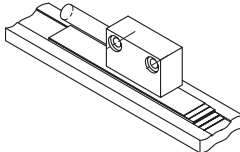

Fig. 5

3.2 Mounting the sensor

Use two M3 screws to fix the magnetic sensor. We recommend to use washers.

- Cable layout should avoid damages due to cable strain or other machine parts. If necessary use a drag chain or protective hose and provide for strain relief. Zur Zugentlastung können die mitgelieferten Kabelschellen eingesetzt werden.

- **Sensor must be aligned correctly with respect to the counting direction** (see fig. 6).

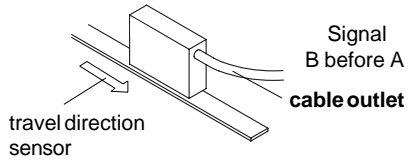
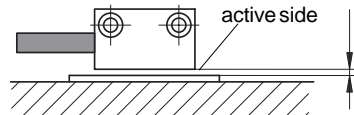

Fig. 6: Definition of counting direction / mounting

- When mounting the magnetic sensor, ensure that the gap between strip & sensor and the max. admissible deviation are maintained over the total measuring length! (see fig. 7)

The max. gap is 0,4mm. Sensor must not touch the magnetic strip.



Gap between sensor and magnetic strip:
max. 0,4mm

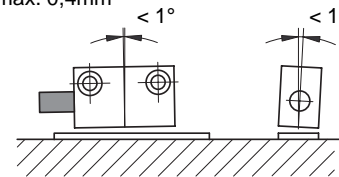

Max. deviation

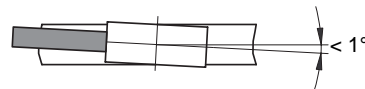

Fig. 8: Mounting of sensor

3.3 Mounting the translation module

The device has been designed for mounting with screws. The lateral holes in the flanges are for direct fixing with screws. (see fig.9)

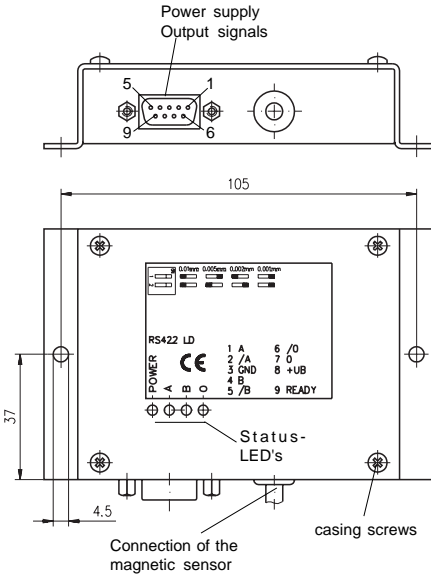

Fig.9: Mounting / connections

4. Electrical connection



Magnetic sensor and translation module are supplied with ready made cable and sensor connection. Any modification, for example by a cable extension, is not permitted.

- Wiring must only be carried out with power off!
- Check all lines and connections before switching on the equipment.

Interference and distortion

All connections are protected against the effects of interference. **The location should be selected to ensure that no capacitive or inductive interferences can affect the sensor or the connection lines!** Interference can be caused by motors, switch gear, cyclic controls and contactors. Suitable wiring layout and choice of cable can minimise the effects of interference.

The following points should be observed:

- Only screened cable should be used. Wire cross section is to be at least 0,14 mm², max. 0,5 mm².
- Wiring to the screen and ground (0V) must be

secured to a good point. Ensure that the connection of the screen and earth is made to a large surface area with a sound connection to minimise impedance.

- The sensor should be positioned well away from cables with interference; if necessary a **protective screen or metal housing** must be provided. The running of wiring parallel to the mains supply should be avoided.
- Contactor coils must be linked with spark suppression.

Power supply

is made via mains connection on rear of the device. The correct supply voltage is indicated in the delivery documentation:

**24 VDC -20% ... +20% or
5 VDC -5% ... +5%**

Connection of the translation module

Output signals and voltage supply are connected to the 9-poles D-Sub terminal strip. (see fig.9)

Attention ! Fixing of the D-Sub plug to the socket is to be made by using the screws on the plug. This will guarantee a neat and effective connection.



Pin No.	Signal
1	A
2	A/
3	GND
4	B
5	B/
6	0/
7	0
8	+U _B
9	Ready

5. Parameters

Before powering the AS100, the unit can be programmed. Please proceed as follows:

- Loosen the 4 screws on the casing.
- Open the casing.
- Carry out DIP-switch setting according to fig. 4.

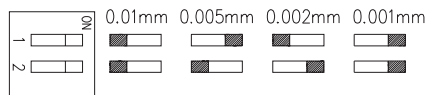

Fig. 10: Parameter setting, position of the DIP switches

Standard parameter setting

Unless specified otherwise, parameters are pre-set as follows:

Resolution: 0.001 mm

6. Output signals

The magnetic length information collected by the magnetic sensor is converted by the translation module into incremental output signals.

Phase difference t_w

The phase difference t_w is shown below:

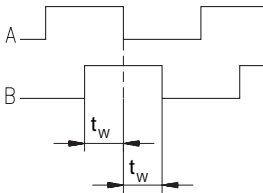

Fig. 10: Phase difference t_w

Formula: $t_w = (976 \times \text{res.} - V \times 50) : V$ (in nanoseconds)

t_w = phase difference in nanoseconds

res. = programmed resolution

V = travel speed in m/s



Attention! The output signals are almost speed-proportional. But due to underlying interpreting procedure, burst signals may arise burst signals at speeds $>4\text{m/s}$. This should be considered when planning position control systems.

Signal sequence

The zero reference signal is issued every 1 mm, irrespective of the resolution.

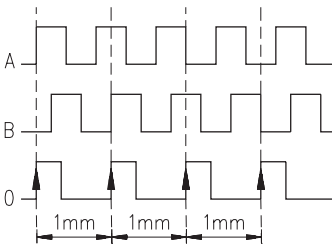

Fig. 11: Output signals A and B with reference signal

Ready signal

The ready output allows the recognition of defective states by the follower controls. The output is activated (active low) whenever the sensor signals are disturbed.

Ready high: initialized and undisturbed

Ready low: disturbed

7. Commissioning

When mounted and connected correctly, the translation module can be switched on.

Initialization of the AS100 is carried out automatically as soon as the device is switched on. The 'POWER'-LED on the device's top glows.

As soon as the magnetic sensor moves, the A and B LEDs start flickering.

8. Calibration

The translation module AS100 is one component of an incremental measuring system. For absolute measuring the system must be adjusted to a defined reference point (calibrated). This can for example be achieved by linking the reference signal with the signal issued by a reference point source REF (eg. cam switch or proximity switch). If the follower electronics are able to recognize signal edges, the reference value can be adjusted with a repeat accuracy of 0,01 mm.

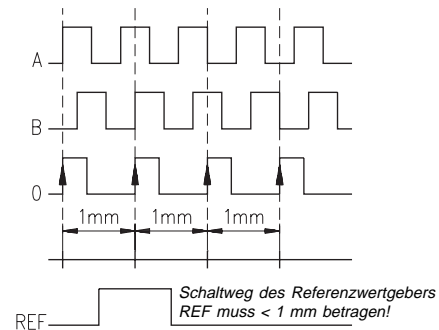

Fig. 12: Principle of calibration

Attention! The index signal is generated independent from signal A and B.



9. Joining magnetic strips together

For some applications it may be necessary to extend the magnetic strip. The magnetic strip can be cut and rejoined using standard tools.

But however carefully this is done the accuracy of the strip at the join will be impaired (error of at least 0,1 ... 0,2 mm).

The following tools / accessories are required:

- magnet magnifier, magnetic foil or metal dust
- rule or suitable tool
- compass needle

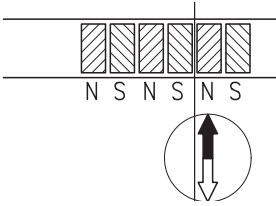

Fig. 13: Determination of the pole position. Cutting the magnetic strip

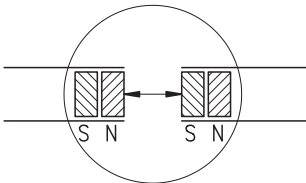

Fig. 14: Determination of the pole position. Joining the magnetic strip

Steps

- If there is a cover strip, this is to be removed first.
- To determine the pole division either use metal dust, a magnet magnifier or magnetic foil.
- If necessary, use a compass needle to determine the location of the poles on the magnetic strip (fig. 13).
- Use a rule and a sharp knife to cut the magnetic strip at a right angle. Then also cut the carrier strip accordingly.
- Previous steps are to be repeated with the other part of strip.
- Check polarity before joining the two parts. Both ends must attract each other (if necessary, use compass needle). In case both ends have

the same polarity, shorten one end by a half pole division (fig. 14).

- Join the two ends closely together and add the cover strip.

10. Maintenance magnetic strips

We recommend cleaning the magnetic strip's surface from time to time with a soft rag. This avoids dirt (dust, chips, humidity ...) sticking to the strip.

11. Trouble shooting

The translation module AS100 is only **one** component of the magnetic strip length measuring system. Error states can be caused by all components. Therefore, you should proceed very systematically during error search:

- First check all supply voltages.
- Are cables, plugs or screwed connectors defective or loose?
- Disconnect the follower electronic and check whether the translation module's output signals are available. The LEDs must light up as soon as the sensor moves.
- Check whether parameter programming is attuned to the follower electronics (counting frequency, resolution, output circuit).

Below are some typical errors which may occur during installation and operation:

- Magnetic strip incorrectly mounted (active surface must be mounted towards the sensor) (see chapter 3.1)
- Use of foreign protective strip. Must always be non-magnetic.
- Sensor incorrectly connected.
- Tolerance for the gap between magnetic sensor and magnetic strip not observed over the **total** travel distance. Sensor touches strip (see fig. 7 or 8)
- Cable squeezed / interrupted / cut by sharp edges.
- Sensor's active side not mounted towards the magnetic strip (see fig. 8).
- Sensor has not been aligned according to chapter 3.2

SIKO GmbH
DR.-ING. G. WANDRES

Postanschrift / Postal address:
Postfach 1106
D-79195 Kirchzarten

Werk / Factory:
Weihermattenweg 2
D-79256 Buchenbach

Telefon / Phone 0 76 61 / 3 94 - 0
Telefax / Fax 0 76 61 / 3 94 - 388
Internet www.siko.de

