

AE/1

Translation Module

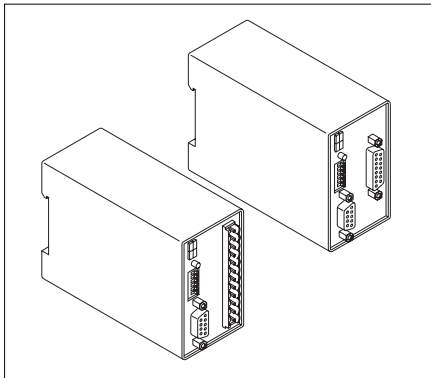

ENGLISH

1. Safety information

In order to carry out installation correctly, we strongly recommend this document is read very carefully. This will ensure your own safety and the operating reliability of the device.

- Your device has been quality controlled, tested and is ready for use. Please respect all warnings and information which are marked either directly on the device or in this document.
- Warranty can only be claimed for components supplied by SIKO GmbH. If the system is used together with other products, the warranty for the complete system is invalid.
- Repairs should be carried out only at our works. If any information is missing or unclear, please contact the SIKO sales staff.

2. Identification

Please check particular type of unit and type number from the identification plate. Type number and the corresponding execution are indicated in the delivery documentation.

3. Installation

The unit should be used only according to the protection level provided. Protect the AE/1, if necessary, against environmental influences such as sprayed water, dust, knocks, extreme temperatures.

Translation module AE/1 has been designed for

mounting on standard rails accord. to DIN EN 50022. The unit can be snapped onto the rail from the front; for dismounting use a screw driver to lift - against the spring's pressure - one of the downside snap elements and to remove AE/1 from the rails.

Attention: There is free access to connections which are live (protection class IP20!). Adequate access protection should be provided.



4. Electrical connection

- Switch power off before plugs are inserted or removed.
- Wiring must only be carried out with power off!
- Provide stranded wires with ferrules.
- Check all lines and connections before switching on the equipment.
- If AE/1 is used in combination with drive systems, you must provide additional safety protection, eg. limit switches or other interlocking systems.

Interference and distortion

All connections are protected against the effects of interference. **The location should be selected to ensure that no capacitive or inductive interferences can affect the translation module or the connection lines!** Suitable wiring layout and choice of cable can minimise the effects of interference (eg. interference caused by switching power supplies, motors, cyclic controls and contactors).

Necessary steps:

- Only screened cable should be used. Screen should be connected to earth at both ends. Wire cross section is to be at least 0,14 mm², max. 0,5 mm².
- Wiring to the screen and the ground (0V) must be secured to a good point and a large surface area to allow minimum impedance.
- The unit should be positioned well away from cables with interference; if necessary a **protective screen or metal housing must be provided**. The running of wiring parallel to the mains supply should be avoided.
- Contactor coils must be linked with spark suppression.

Pin connection

is made via the sockets on front of the AE/1 (fig. 8). Depending on the type of AE/1, use for connection either 12-pole multipoint or a 15-pole SUB-D connector.

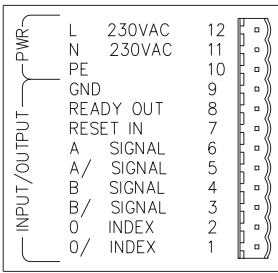

Fig. 1: 230/110 VAC Pin plug

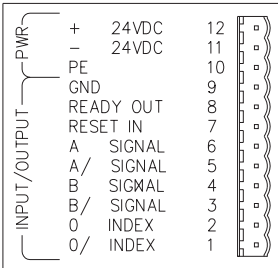

Fig. 2: 24 VDC Pin plug

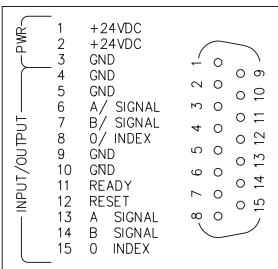

Fig. 3: 24 VDC SUB-D

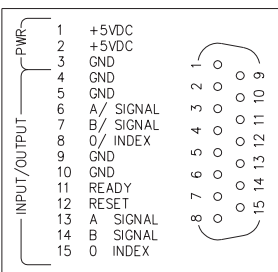

Fig. 4: 5 VDC SUB-D

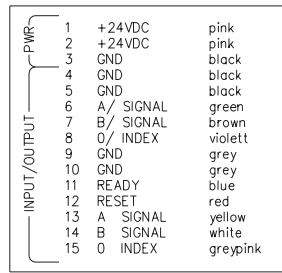

Fig. 5: 24 VDC SUB-D with cable

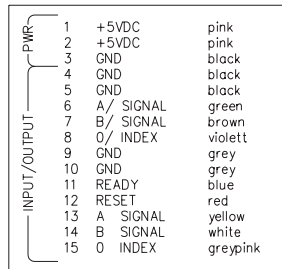

Fig. 6: 5 VDC SUB-D with cable

Connection of the magnetic sensor

The sensor is connected via the screened and ready made SUB-D socket on front of the unit (fig. 8). Connect the SUB-D plug firmly with the screws to the socket. This gives a firm and stable electrical connection to ground.

Attention! Any modification, for example by a cable extension, is not permitted.



5. Parameters

Parameter setting via DIP-switches

Parameter setting is made via a 6 poles DIP-switch on front of the unit.

- output circuit
- ERROR function
- resolution and
- counting frequency / signal distance

Please check the setting of the DIP-switches before the first use and, if necessary, adapt it to your application. The setting of the switches can at any time, even during operation, be adjusted and become immediately effective.

Basic setting ex works:

Output circuit: TTL
 ERROR function: ON
 Resolution: 0.01 mm
 Counting freq. / sign. distance: 1 MHz / 1 ms

ON ←	1	PushPull	1	TTL
1	2	Err Off	2	On
2	3 4	1.0mm	3 4	0.1mm
3	3 4	0.05mm	3 4	0.01mm
4	5 6	125kHz	5 6	250kHz
5	5 6	0.5MHz	5 6	1MHz
6				

Fig. 7: DIP-switches

Relation travel speed / resolution

Resolution [mm]	Speed max. [m/s]			
	Signal distance			
	A/B signal	tw [ms] / count.	freq. [Hz]	
0.01	1/1M	2/500k	4/250k	8/125k
0.05	5	5	5	4
0.1	5	5	5	5
1.0	5	5	5	5

6. Operating elements

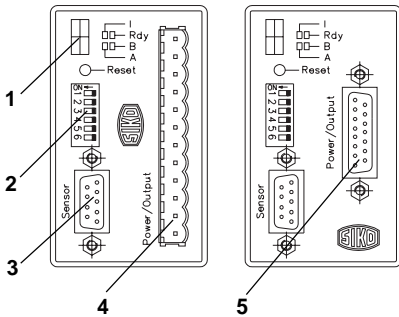

Fig. 8: AE/1's front

- 1: LED block
- 2: DIP-switches
- 3: 9 poles SUB-D socket for sensor connection
- 4: 12 pole pin plug strip
- 5: 15 poles SUB-D plug

LED block for status messages

Yellow LED 0: comes on when reference signal (0) is active.

Red LED A, B: comes on when output channels A, B are active.

Green LED Rdy: AE/1 is ready for use.

Red LED Rdy : supply voltage applied, but device is **not** ready for use.

7. Output signals

The magnetic length information collected by the magnetic sensor is converted by the translation module AE/1 into incremental output signals. The signal's conversion depends on the travel speed. If travels speed is > 0.1 m/s, the signals are issued at regular intervals as pulse packages.

Attention! In case of travel speed > 0.1 m/s the output signals do not totally correspond to signals as issued by incremental rotary encoders. This should be taken into account when planning the setup of the measuring system, especially position control systems.



Signal sequence

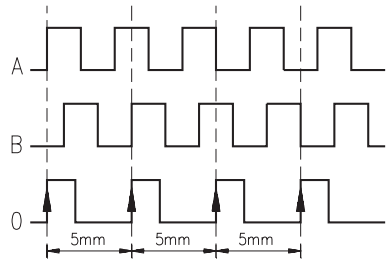

Fig. 9: Output signals A/B with reference signal

Example: Resolution 1 mm

The zero reference signal is issued every 5 mm, irrespective of the resolution.

Signal shapes

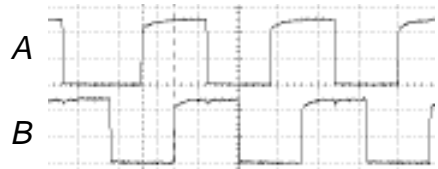

Fig. 10: Signals A/B phase-shifted by 90°

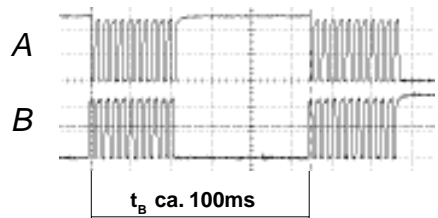

Fig. 11: Output signals during burst operation

Ready signal

The ready output allows the recognition of defective states by the follower controls. The output is activated (active low) whenever the sensor signals are disturbed (also see chapter 10, *Trouble shooting*). This function can be deactivated.

Ready high: initialized and undisturbed

Ready low: disturbed

The ready state is displayed by a green LED on the casing's front.

8. Commissioning

When mounted and connected correctly, translation module AE/1 can be switched on. Ensure that the magnetic sensor is connected to the translation module and that the sensor moves at a defined distance along the magnetic strip.

The device must now be initialized:

Either manually by pressing the reset key on the AE/1's front (fig. 8) or automatically by activating the signal on the reset input, eg. by a ground switching contact or a proximity switch (NPN, N.O.). After initialization the green Rdy-LED glows and as soon as the magnetic sensor moves, the A and B LEDs start flickering.

9. Calibration

The translation module AE/1 is one component of an incremental measuring system. For absolute measuring the system must be adjusted to a defined reference point (calibrated). This can for example be achieved by linking the reference signal with the signal issued by a reference point source REF (eg. cam switch or proximity switch). If the follower electronic is able to recognize signal edges, the reference value can be adjusted with a repeat accuracy of 0,01 mm.

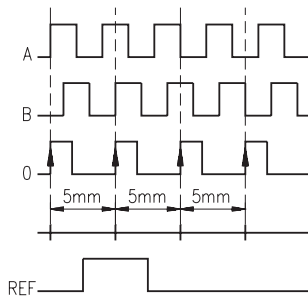

Fig11: Principle of calibration

Example: Resolution 1 mm

Signal travel of the reference point source REF is to be < 5 mm!

Calibration: Relation travel speed/resolution

Resolution [mm]	Vmax [m/s]
0.01	0,1
0.05	0,5
0.1	1
1.0	5

10. Trouble shooting

Translation module AE/1 is only **one** component of the magnetic strip length measuring system. Error states can be caused by all components. Therefore, you should proceed very systematically during error search:

Check all supply voltages, cables, plugs or screwed connectors.

Check the tolerance for the gap between magnetic sensor and magnetic strip.

Disconnect the follower electronic and check whether the follower electronic's output signals are available. The LEDs must light up as soon as the sensor moves.

Push the RESET-button.side. For dismounting press locking down.

SIKO GmbH
DR.-ING. G. WANDRES

Postanschrift / Postal address:
Postfach 1106
D-79195 Kirchzarten

Werk / Factory:
Weihermattenweg 2
D-79256 Buchenbach

Telefon / Phone 0 76 61 / 3 94 - 0
Telefax / Fax 0 76 61 / 3 94 - 388
Internet www.siko.de