

# Magnetic Sensor MSA111

## Magnetic Strip MBA111



The sensor scans the absolute lane information of the magnetic tape MBA111. If combined with translation module AEA111, sensor data are processed for further use. In addition there's an analog 1Vss Sin/Cos signal for real time data interpretation.

**SIKO GmbH**

**Address**  
Weihermattenweg 2  
79256 Buchenbach

**Telephone**  
+49 7661 394-0  
**Fax**  
+49 7661 394-388

**eMail**  
info@siko.de  
**Internet**  
www.siko.de

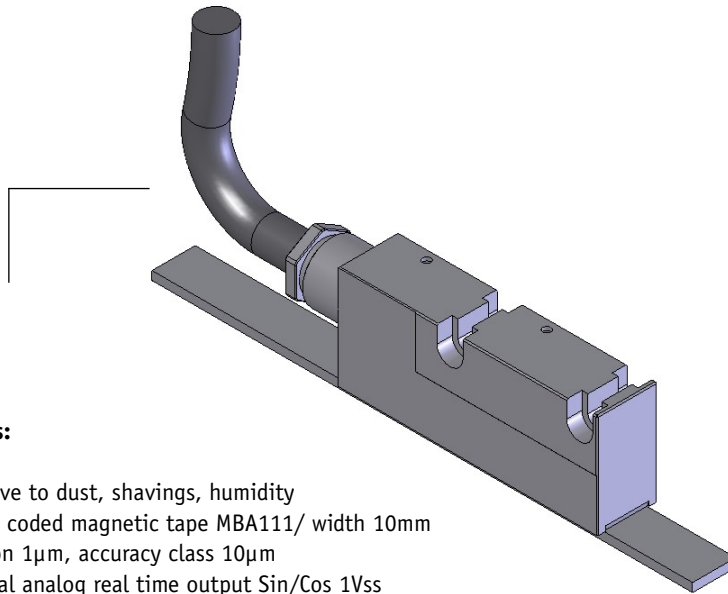

**Features:**

- insensitive to dust, shavings, humidity
- absolute coded magnetic tape MBA111/ width 10mm
- resolution 1µm, accuracy class 10µm
- additional analog real time output Sin/Cos 1Vss
- signal period 1mm

Feature	Order text	Additional information
Connection	E6X <b>A</b>	standard
Cable length L (in m)	... <b>B</b> max. 20m	standard 1,0m
Magnetic strip length	<b>C</b> 0,2...4,07m in 1cm steps	
Adhesive tape	TM <b>D</b> yes TO no	
Cover strip	AM <b>E</b> yes A0 no	

Your ordering:  -  -  (magnetic sensor)

Your ordering:  -  -  -  (magnetic strip)

# Magnetic Sensor MSA111

## Magnetic Strip MBA111

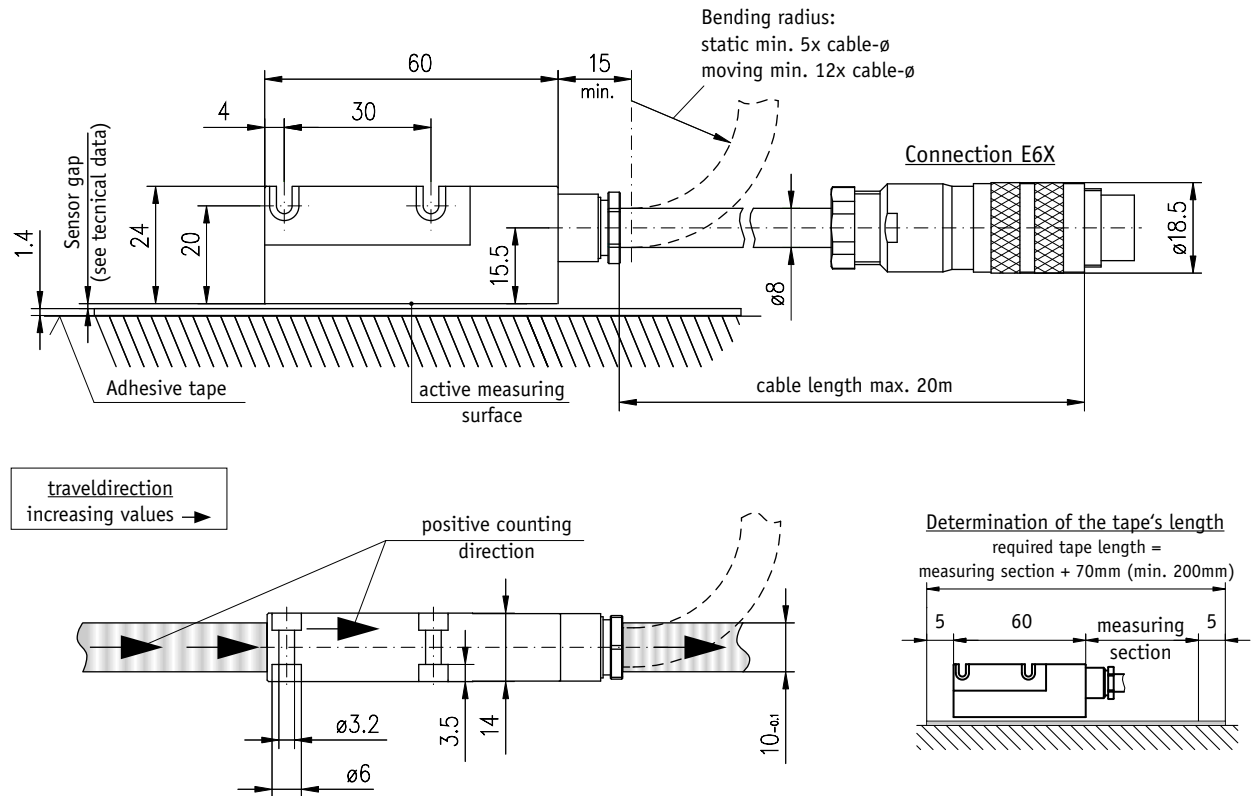

### Technical data

#### Mechanical data:

Housing	aluminium
Sensor cable	PUR

#### Electrical data:

Realtime requirements	real-time signal processing	Sin/Cos output
Interference protection class	3	IEC-61000-6-2
Test mark	CE	

#### Environmental conditions:

Operating temperature	-10°C ... +60°C
Storage temperature	-30°C ... +80°C
Humidity	100% rF, condensation permitted
Type of protection	IP67

#### System data:

Resolution SSI	max. 1µm
Suitable magnetic sensor	MBA111
Pole length	1mm
Period length Sin/Cos output	1000µm
Travel speed static operation	< 0.3m/s (SSI)
Travel speed dynamic operation	< 10m/s (Sin/Cos)
System accuracy	±10µm
Repeat accuracy	max. ±2µm
Sensor (active measuring surface)/magnetic strip (top) gap	max. 0.1mm (with cover strip on magnetic strip) max. 0.2mm (without cover strip on magnetic strip) lateral misalignment ±0.3mm
Temperature coefficient/strip	(11±1)×10 <sup>-6</sup> /K
Measuring length	max. 4000mm

### Additional information