

Profile

- Max. resolution 0.018° with MR320
- Max. 5000 pulses/revolution with MR320 and MBR320 (250 poles)
- Max. 20 000 increments/revolution with quadrature evaluation
- Repeat accuracy of ±1 increment

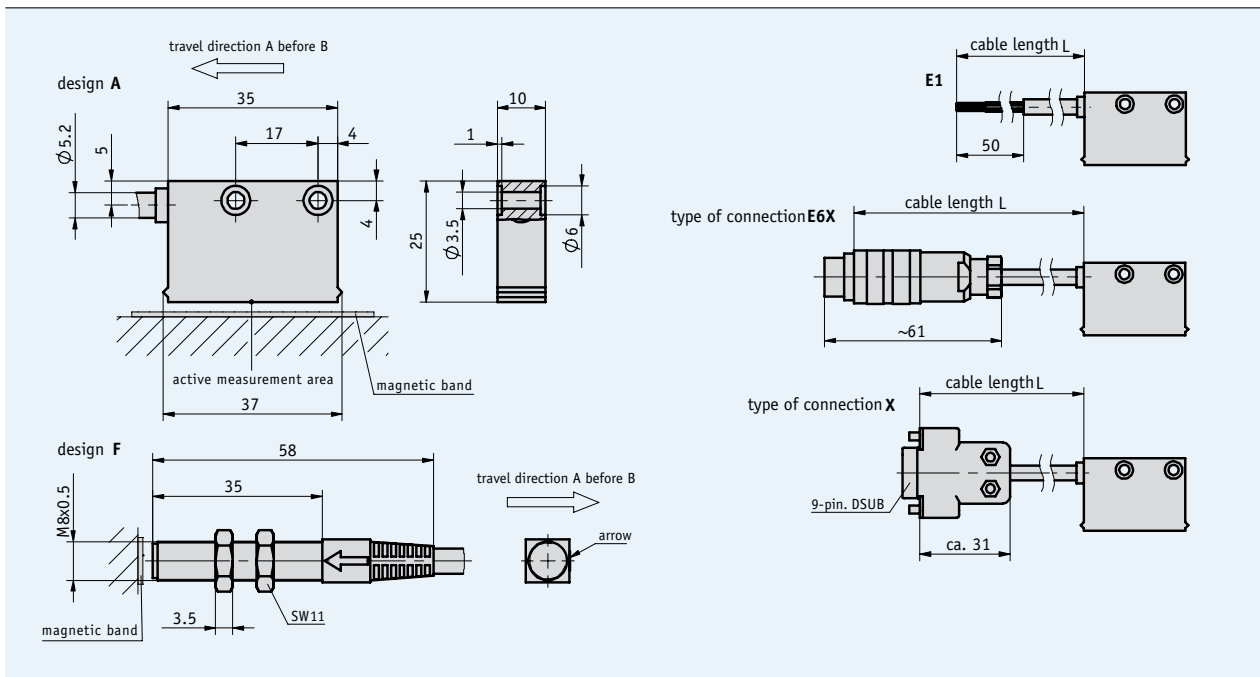

Mechanical data

Feature	Technical data	Additional information
Scale embodiment	MR320 MBR320 MRI01	
System accuracy	± 0.1°	
Repeat accuracy	± 1 increment	
Sensor/ring reading distance	0.1 ... 2 mm 0.1 ... 0.4 mm	with reference signals 0, I with reference signal R
Circumferential speed	max. 25 m/s	max. referencing speed 3.2 m/s
Housing	rectangular housing, plastic red; round housing, steel	
Sensor cable	PUR	
Operating temperature	-10 ... +70 °C	
Storage temperature	-30 ... +80 °C	
Humidity	100 % rh	condensation permitted
Protection category	IP67	
Vibration resistance	10 g/50 Hz	
Max. measuring length	infinite	

Electrical data

Feature	Technical data	Additional information
Operating voltage	24 V DC $\pm 20\%$ 5 V DC $\pm 5\%$	reverse-polarity protection on UB no reverse-polarity protection on UB
Current consumption	max. 70 mA	24 V no load
Type of connection	flying leads round connector D-SUB 9-pin	
Output circuit	PP LD TTL	PP only with 24 V
Output signals	A, /A, B, /B, option: I, /I, or R, /R	quadrature signal
Max. pulses/revolution	max. 5000 pulses/revolution max. 20000 increments/revolution	number of poles 250 when combined with MR/MBR 320
Pulse width of reference signal	1 increment	
Scaling factor	1, 4, 5, 8, 10, 16, 20	
Jitter	<15 %	with reading distance of 0.5 mm
Interference protection class	3	according to IEC 801
Real-time requirement	real-time signal processing	

Signal forms

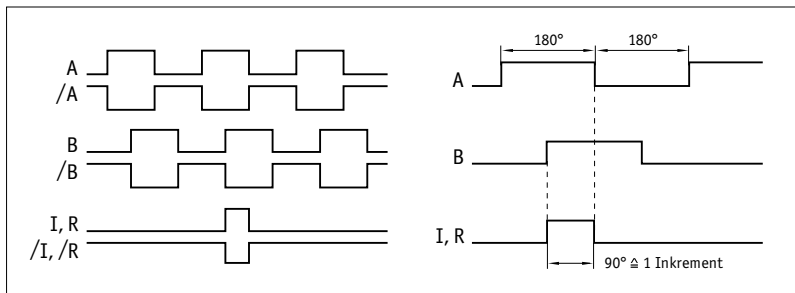

⚠ The logical condition of signals A and B is not defined in reference to the index signal I or the reference signal R. It can deviate from the signal form.

Pin assignment

non-inverted

Signal	E1	E6X	E8X
A	red	3	3
B	orange	4	4
+UB	brown	2	2
GND	black	1	1
N.C.		5,6,7	5,6,7,8,9

inverted

Signal	E1	E6X	E8X
A	red	1	1
B	orange	2	2
+UB	brown	4	4
GND	black	5	5
A/	yellow	6	6
B/	green	7	7
N.C.		3	3, 8, 9

inverted with reference signal

Signal	E1	E6X	E8X
A	red		
B	orange	2	2
I	blue	3	3
+UB	brown	4	4
GND	black	5	5
A/	yellow	6	6
B/	green	7	7
I/	violet	8	8
N.C.			9

Mounting instruction

On systems with reference points on the magnetic ring, please ensure the correct alignment of the sensor and band.

Reference signal	O, I	R
Sensor/band reading distance A	max. 2 mm	max. 1.5 mm
Lateral offset B	max. ±2 mm	max. ±0.5 mm

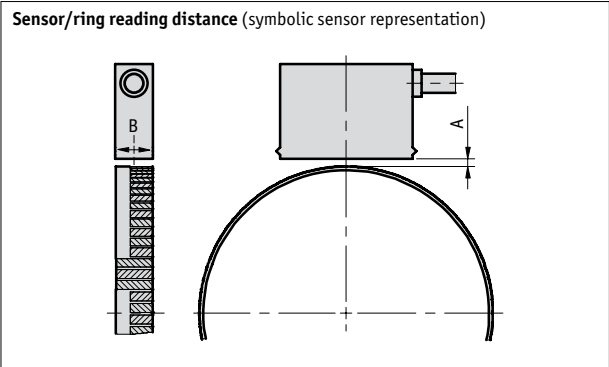

Order

Order table

Feature	Order data	Specifications	Additional information
Operating voltage	4	24 V DC ±20 %	reverse-polarity protection
	5	5 V DC ±5 %	
Sensor design	A	rectangular	
	F	round	
Type of connection	E1	flying leads	
	E6X	round connector without mating connectors	
	E8X	D-SUB 9-pin without mating connectors	
		cable extensions on request	
Cable length L	...	D 1 ... 20 m, in steps of 1 m	
Output circuit	PP	push-pull	only operating voltage 4
	LD	line driver	
	TTL		only with non-inverted output signal, max. 5 m cable length
Output signal	NI	non-inverted	with reference signal I or R
	I	inverted	
Reference signal	O	without	not with scaling factor 1
	I	index periodic	
	R	index fixed	
Scaling factor	...	H 1, 4, 5, 8, 10, 16, 20	F design only possible with scalings 4, 8

Order code

MSK320 - - - - - - - -

Scope of delivery: MSK320, User information, Allen fastening screws M3 x 14 mm ISO 4762, lock washers M3 DIN 7980, strain relief for sensor cable

Additional information:

Short Description, Technical Details
Product Overview

Page 136 cont.
Page 4 cont.