

Profile

- Max. resolution 40 μm
- Repeat accuracy ±0.04 mm
- Works with magnetic band MB320
- Reading distance up to 2 mm

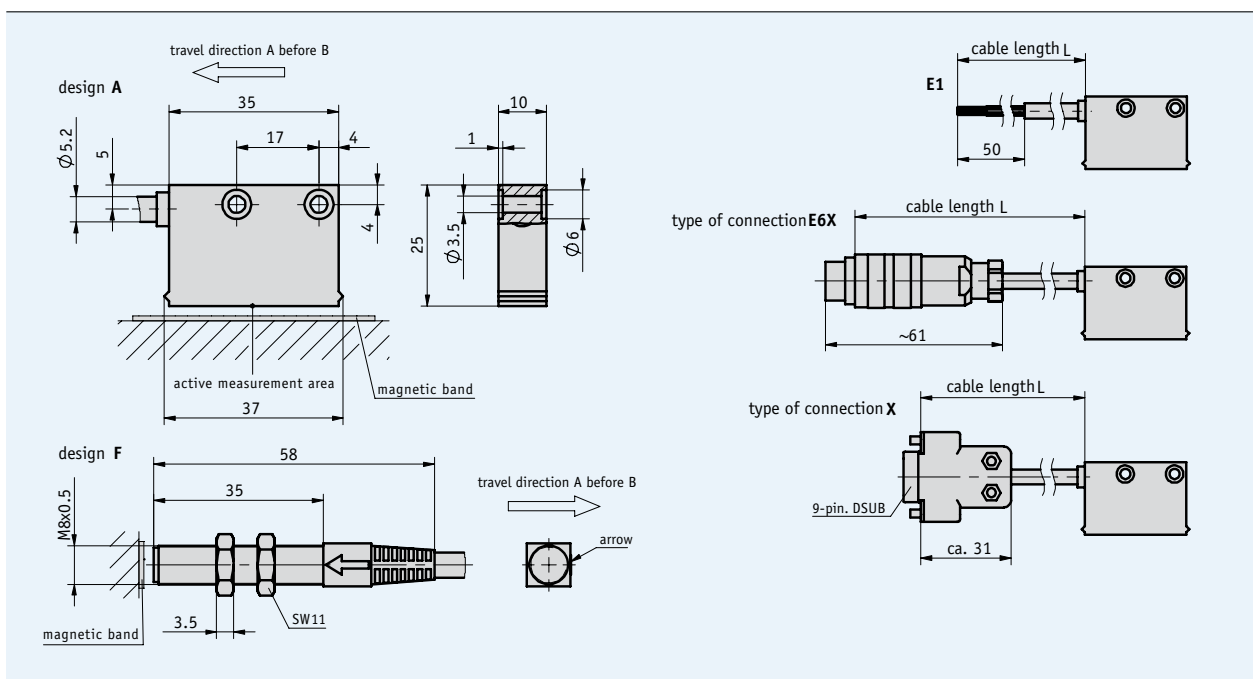

5.2

Mechanical data

Feature	Technical data	Additional information
Scale embodiment	MB320	
System accuracy	$\pm(0.1 + 0.01 \times L)$ mm, L in m	
Repeat accuracy	±1 increment	with $T_U = 20$ °C
Sensor/band reading distance	0.1 ... 2 mm 0.1 ... 1.5 mm	with reference signals 0, I with reference signal R
Travel speed	max. 25 m/s	max. referencing speed 3.2 m/s
Housing	rectangular housing, plastic red; round housing, steel	
Sensor cable	PUR	
Operating temperature	-10 ... +70 °C	
Storage temperature	-30 ... +80 °C	
Humidity	100 % rh	condensation permitted
Protection category	IP67	
Vibration resistance	10 g/50 Hz	
Max. measuring length	infinite	in steps of 90 m

Electrical data

Feature	Technical data	Additional information
Operating voltage	24 V DC ±20 % 5 V DC ±5 %	reverse-polarity protection on UB no reverse-polarity protection on UB
Current consumption	max. 70 mA	24 V no load
Type of connection	flying leads round connector D-SUB 9-pin	
Output circuit	PP LD TTL	PP only with 24 V
Output signals	A, /A, B, /B, Option: I, /I, or R, /R	quadrature signal
Pulse width of reference signal	1 increment	
Resolution	0.04, 0.05, 0.08, 0.1, 0.16, 0.2, 0.8 mm	
Jitter	<15 %	with reading distance of 0.5 mm
Interference protection class	3	according to IEC 801
Real-time requirement	real-time signal processing	
Signal level high	>UB - 2.5 V >2.5 V >2.4 V	with PP with LD with TTL
Signal level low	<0.8 V <0.5 V <0.4 V	with PP with LD with TTL

Signal forms

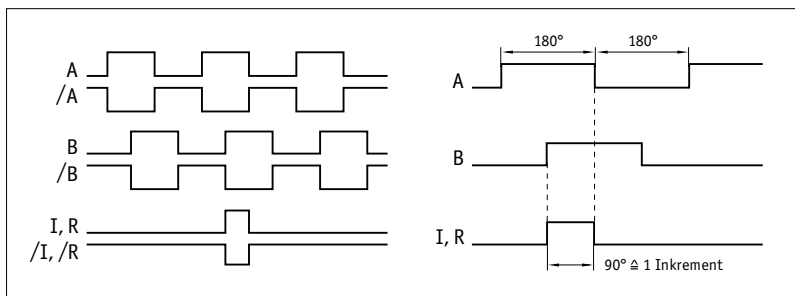

! The logical condition of signals A and B is not defined in reference to the index signal I or the reference signal R. It can deviate from the signal form.

Pin assignment

non-inverted

signal	E1	E6X	E8X
A	red	3	3
B	orange	4	4
+UB	brown	2	2
GND	black	1	1
N.C.		5,6,7	5,6,7,8,9

inverted

signal	E1	E6X	E8X
A	red	1	1
B	orange	2	2
+UB	brown	4	4
GND	black	5	5
A/	yellow	6	6
B/	green	7	7
N.C.		3	3, 8, 9

inverted with reference signal

signal	E1	E6X	E8X
A	red	1	1
B	orange	2	2
I	blue	3	3
+UB	brown	4	4
GND	black	5	5
A/	yellow	6	6
B/	green	7	7
I/	violet	8	8
N.C.			9

Mounting instruction

On systems with reference points on the magnetic band, please ensure the correct alignment of the sensor and band (see diagram).

Reference signal	O, I	R
Sensor/band reading distance A	max. 2 mm	max. 1.5 mm
Lateral offset B	max. ±2 mm	max. ±0.5 mm

Sensor/band reading distance (symbolic sensor representation)

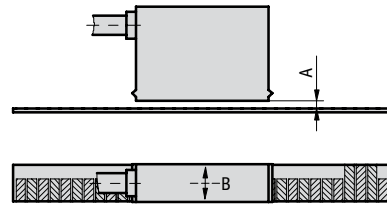

Order

Order table

Feature	Order data	Specifications	Additional information
Operating voltage	4	24 V DC ±20 %	reverse-polarity protection
	5	5 V DC ±5 %	
Sensor design	A	rectangular	
	F	round	
Type of connection	E1	flying leads, 2 m cable	
	E6X	round connector without mating connectors	
	E8X	D-SUB 9-pin without mating connectors	
		cable extensions on request	
Cable length L	...	D 1 ... 20 m, in steps of 1 m	
Output circuit	PP	push-pull	only operating voltage 4
	LD	line driver	
	TTL		only with non-inverted output signal, max. cable length 5 m
Output signal	NI	non-inverted	with reference signal I or R
	I	inverted	
Reference signal	O	without	not possible with resolution 0.8 mm
	I	index periodic	
	R	index fixed	
Resolution	...	H 0.05, 0.1, 0.2, 0.8, 0.04, 0.08, 0.16	F design only possible with resolutions 0.1, 0.2

Order code

MSK320 - - - - - - - -

Scope of delivery: MSK320, User information, Allen fastening screws M3 x 14 mm ISO 4762, lock washers M3 DIN 7980, strain relief for sensor cable

Additional information:

Short Description, Technical Details
Product Overview

Page 46 cont.
Page 4 cont.