

Incremental encoder IV28M/1

Miniature high precision rotary encoder:
The incremental encoder IV28M/1 is very resistant to vibration, dirt and humidity and convincing by its small, compact size.



SIKO GmbH

Address
Weihermattenweg 2
79256 Buchenbach

Telephone
+49 7661 394-0
Fax
+49 7661 394-388

eMail
info@siko.de
Internet
www.siko.de

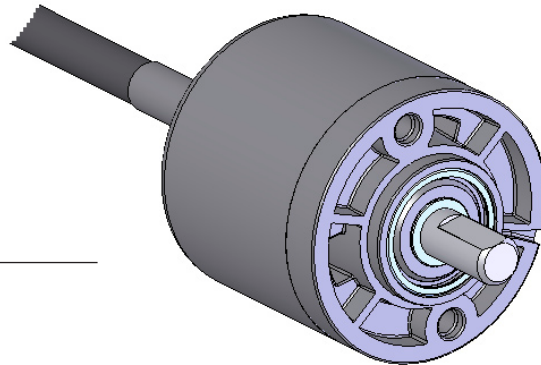

Features:

- Resolution max. 1000 pulses/ revolution
- Output circuit PP, OP, LD5, LD24
- Shaft \varnothing 6mm (max.)
- Protection IP54
- Flange- \varnothing 28mm
- Measuring principle: magnetic scanning

Features	Order text	Additional information
Output signals	ABO A	
	ABI	
	ABX	
Pulses	50 B	in 50-increments max. 1000
	36	
Connection type	E1 C	stripped cable ends standard
	E6X	connector (Fa. Binder)
	E7	connector (Fa. Woodhead Connectivity)
	E12	connector (Fa. Molex)
Position of electrical connection	A D	axial
	R	radial
Cable length (in m)	1,0 E	in 1m steps standard ; max. 10,0m (LD5 max. 3,0m)
	0,07	connection type E7
Output circuit	PP F	push pull, without inverted signals
	OP	push pull, with inverted signals
	LD5	line driver; 5V DC encoder supply
	LD24	line driver; 24V DC encoder supply
Shaft- \varnothing x length (in mm)	5x10 G	
	6x10	
Mounting type	M1 H	

Your ordering: IV28M/1 - A - B - C - D - E - F - G - H

Incremental encoder IV28M/1

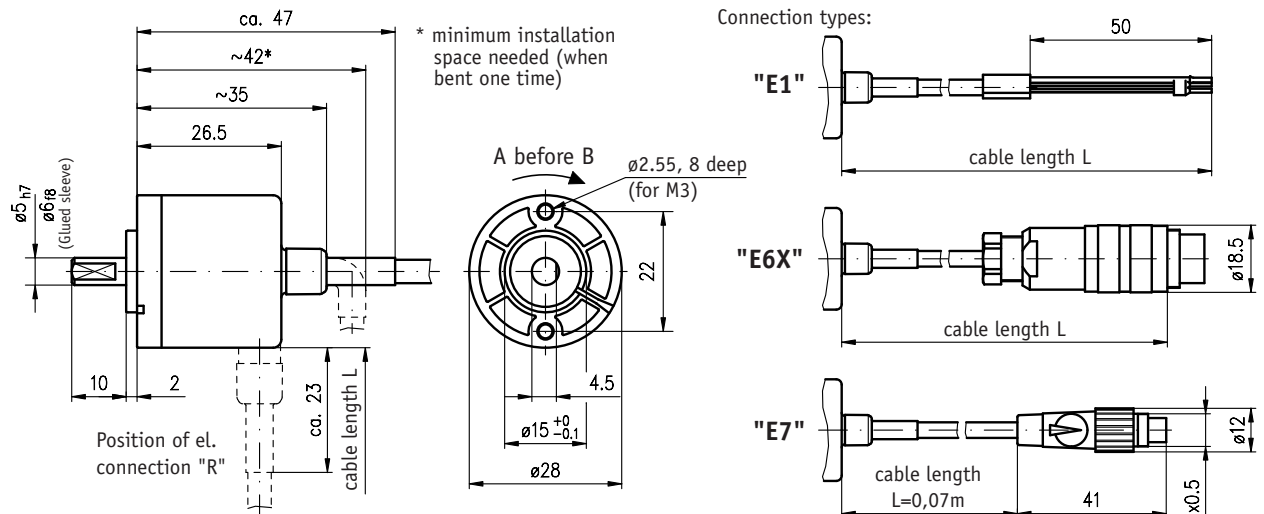

Viewing side = plug-in side (plug pin)

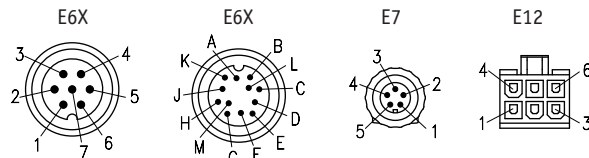

Pin assignment output circuit PP

Signal	GND	+U _B	A	B	0/I	N.C.	screen
E1	grey	brown	yellow	white	green		black
E6X	5	2	4	1	3	6,7	
E7	1	2	3	5	4		
E12	1	2	3	5	6		4

Pin assignment output circuit OP/LD5/LD24

Signal	GND	+U _B	A	/A	B	/B	0	I	N.C.	screen
E1	grey	brown	yellow	pink	white	blue	green	red		black
E6X	K	M	E	F	H	A	C	D	B,G,J,L	

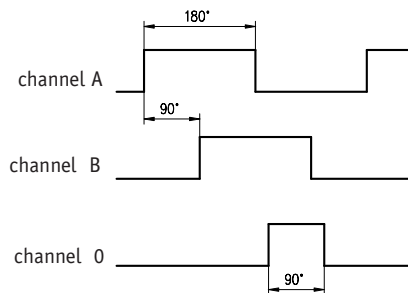

State of signals A and B in regards to the reference signal 0 is not defined and can be different from fig.

Technical Data

Mechanical data:		Additional information	
Speed	max. 6000min ⁻¹		
Moment of inertia	ca. 0.24x10 ⁻⁶ kgm ²		
Weight	ca. 0,1kg		
Protection	IP54		
Working temperature	-20°C ... +70°C		
Storage temperature	-20°C ... +80°C		
Shaft	stainless steel		
Flange/ housing	plastic		
Cable sheat	PUR (E1, E6X); PVC (E7, E12)		
Shock resistance	200g / 6ms		according to DIN-IEC 68-2-27
Vibration resistance	10g / 50Hz		according to DIN-IEC 68-2-6

Elektrical data:

Output circuit	push pull (PP, OP)	line driver (LD5)	line driver (LD24)	
Power supply	+10VDC ... +30VDC	+5VDC ±5%	+10VDC ... +30VDC	
Power cons. iwthout load (typ.)	<25mA	<25mA	<25mA	version ABO
Permitted load/ channel (max.)	±30mA	±30mA	±30mA	
Signal level	high (min.) 29,2VDC low (max.) 0,5VDC	/	/	U _B = 30V, I _{OH} = -30mA U _B = 30V, I _{OL} = 30mA
Polarity protection on U _B	yes	no	yes	
Pulse frequency max.	20kHz (36, 50, 100, 150 pulses); 100kHz (200 ... 800 pulses); 250kHz (850 ... 1000 pulses)			

Accessory	76141	76572	KV...
	mating connector PP (to E6X)	mating connector OP/LD5/LD24 (to E6X)	cable prolagation (to E6X)