

Geared potentiometer GP03

Compact rotary encoder for absolute position sensing with potentiometric output signal or current interface.



SIKO GmbH
Dr.-Ing. G. Wandres

Address
Weihermattenweg 2
D-79256 Buchenbach

Telephone
+49 (0) 76 61 / 394 - 0
Fax
+49 (0) 76 61 / 394 - 388

eMail
info@siko.de
Internet
www.siko.de



Features:

- solid shaft 6 mm
- adaptation to various measurement distances thanks to the broad range of available gear ratios
- compact design
- integrated slip clutch for potentiometer protection
- optional current interface 4... 20 mA
- optional IP65 type of protection for critical environmental conditions

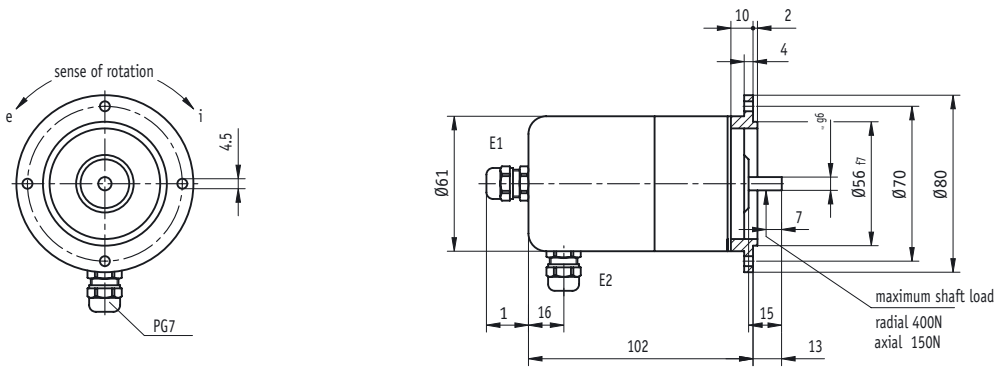

Subject to technical alternation • 11/2002

without transducer

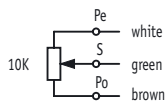

transducer MWI

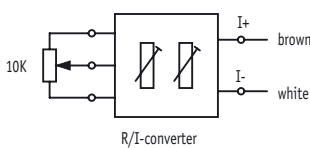

Geared potentiometer GP03

Feature	Order text	Technical data	Additional information
Gear ratio		0.2... 256	
Rotational speed		max. 500 min ⁻¹	depending on gear ratio
Supply voltage		24 V DC ± 20 %	transducer MWI (at ≤ 500 Ohm)
Working temperature		- 20 °C... + 80 °C	
Condensation		not permitted	
Service life - shaft movements		1 x 10 ⁶ (2 x 10 ⁶)	
Test mark/interference prot. class		CE	3 acc. to IEC 801
Type of protection		IP52, IP65	acc. to DIN VDE 0470
Housing		aluminium	
Shaft		blued steel	

Potentiometer electrical values

Resistance tolerance		± 5 %	
Linearity tolerance		± 0.25 %	
Load rating		1 W at 70 °C (potentiometer type 01,02)	2 W at 70 °C (potentiometer type 03)
Range of rotation		340° ± 5°	1 filament (mechanically straight through)
		3600° + 10°	10 filaments
Standard terminal resistor		0.5 % or 1 Ohm	(the higher value applies)

Ordering data

Gear ratio	...	A	max. 256 others on request	
Drive shaft	V/6	B	Solid shaft ø special shafts on request	standard
Type of connection	E1 E2	C	axial cable outlet radial cable outlet	
Cable length (in m)	OK ...	D	max. 10.0 m	connection via integrated terminal board
Potentiometer type	01 02 03	E	1 filament 10 filament/ wire 10 filament	
Resistance kOhm	1 2 5 10	F	1 kOhm 2 kOhm 5 kOhm 10 kOhm	
Transducer	OMW MMW	G	without with	standard current interface 4... 20mA
Sense of rotation	i e	H	see drawing see drawing	only with transducer only with transducer
Type of protection	IP52 IP65	I		standard
Number of revolutions used	...	K	e.g., „140“	only for IP 65 and IP68 with transducer: actual measuring distance (number of shaft revolutions used)

Subject to technical alternation • 11/2002

Your ordering data: GP03 - A - B - C - D - E - F - G - H - I - K