

WIRE-ACTUATED ENCODERS

INNOVATIVE WIRE-ACTUATED ENCODERS ENABLE VARIABLE POSITION MEASUREMENT IN PISTON ACCUMULATORS, AS WELL AS IN STANDARD AND TELESCOPIC HYDRAULIC CYLINDERS

The new SGH25 wire-actuated encoder from Siko is characterized by a measurement range of up to 2.5m – compared with 1m in the SGH10 basic model – and an extremely long service life. The variety of interfaces meets the very highest requirements, even in applications that are critical for safety. With this performance profile, the wire-based position sensor is suitable for applications in mobile machines such as dumper trucks, excavators and agricultural machinery, where it measures the position of hydraulic and telescopic cylinders and communicates it to the machine control system via integrated communication protocols.

Extended measurement ranges

The SGH25's big brother, the SGH50, covers large measurement ranges up to 5m. The SGH series can be integrated directly into hydraulic cylinders. A newly developed plastic provides a strong design and extends the fluid temperature range from the previous 85°C to 105°C.

Robust in every respect

As far as shock and vibration resistance are concerned, SGH sensors set new standards. The SGH25 has been tested to the toughest vibration standards, which are otherwise used for helicopter drives, and the product easily withstands individual shocks of up to 100 times the force of gravity. Its flexible cable cushions the hardest impacts. The hydraulic medium also helps to damp any vibrations.

Teach-in measurement lengths

With the integrated teach-in function, the measurement length of the sensor can be set individually. The SGH25 can cover a multitude of measurement

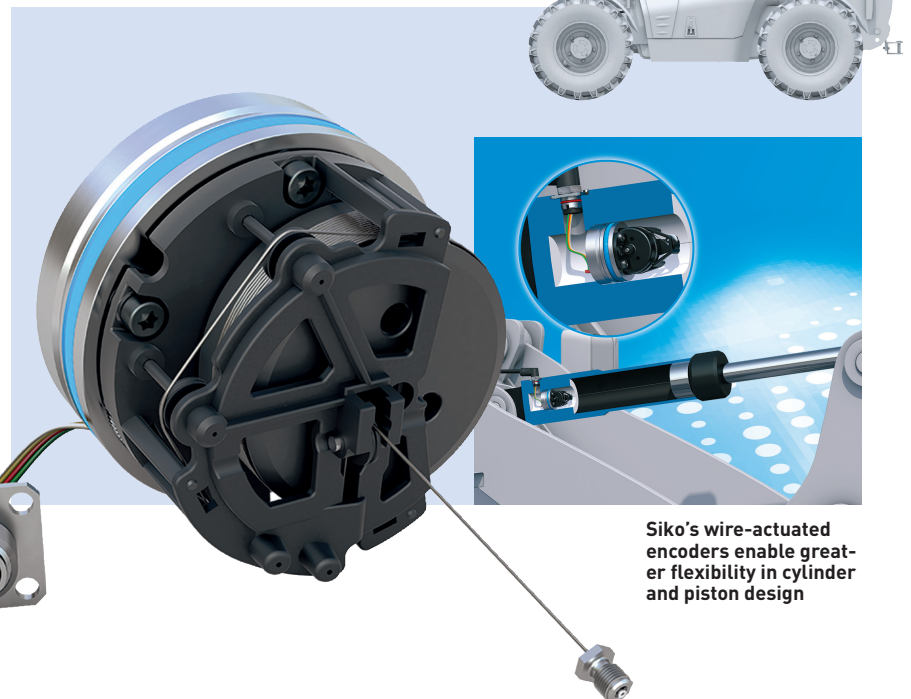

Siko's wire-actuated encoders enable greater flexibility in cylinder and piston design

lengths (0-2.5m), so the number of variants and the stock requirements for spare parts is reduced. Another feature of the position sensor is a KV1H plug connection. This modular plug connection system has the high protection rating of IP69K.

The SGH25 was developed specially for extreme conditions in mobile hydraulics that are mainly used in agricultural machinery or construction machines. The resilience required for this has been designed and tested both electronically and mechanically for the service life of a cylinder.

Safety first

The SGH25 is available with analog interfaces and with CANopen or SAE J1939 protocols for transmitting data between the SGH sensor and the machine control system. Redundant versions with CAT3, performance level D-PLd, meet the highest requirements

for safety-critical applications in accordance with EN13849. There is a choice with safety variants between a redundant analog interface, redundant CANopen, redundant SAE J1939 and CANopen-safety.

Piston boring not required

For cylinder manufacturers, the use of SGH position sensors offers great potential for savings, as the cable-based design concept makes hollow boring of the piston superfluous. The SGH wire-actuated encoder can also be installed in telescopic cylinders, providing a major competitive advantage over traditional measurement systems.

Mathias Roth is mobile automation sector manager at Siko GmbH
www.siko-global.com/p/sgh25



FREE READER INQUIRY SERVICE

To find out more about this advertiser visit ukimediaevents.com/info/ivtch