

SIKO

Multiplexing Control

MX08/2



Manual



The right step

SIKO GmbH
DR.-ING. G. WANDRES



Postal address:

P.O. Box 1106

D-79195 Kirchzarten

Factory:

Weihermattenweg 2

D-79256 Buchenbach

Phone (+49) 76 61 / 3 94 - 0

Telefax(+49) 76 61 / 3 94 - 88

Telex 7 722 715 SIKO D

Subject to technical modifications !

© SIKO GmbH

Contents**Chapter 1: Summary description**

1.1	SIKONETZ field-bus system	1 - 2
1.2	Functions of the MX08/2	1 - 4
1.3	... an MX08/2 application example	1 - 6

Chapter 2: Setting up

2.1	General information and recommendations	2 - 2
2.2	Mechanical installation, mounting/dismounting	2 - 4
2.3	Electrical installation	2 - 5
2.4	Commissioning	2 - 7

Chapter 3: Technical data

3.1	Identification plate, identification key	3 - 2
3.2	Technical data	3 - 3
3.3	Connections	3 - 4
3.4	Dimensions	3 - 5

Chapter 4: Function

4.1	Set up and block diagram	4 - 2
4.2	Significance within the SIKONETZ field-bus system	4 - 3
4.3	Interaction with other SIKONETZ devices	4 - 3
4.4	Interaction with a central control	4 - 4
4.5	MX08/2 as interface converter	4 - 5
4.5	When switched on	4 - 7
4.6	Address setting within the SIKONETZ field-bus system	4 - 9

Chapter 5: Operation

5.1	Operating elements	5 - 2
.1	Keyboard	5 - 3
.2	Keyboard table	5 - 4
.3	Display	5 - 5
.4	Display of long lists via cursor	5 - 6
5.2	Access rights	5 - 7
5.3	Main menu	5 - 13
.1	Menu 'device' parameters'	5 - 15
.2	Menu 'Position display'	5 - 20
.3	Menu 'Axis positioning'	5 - 27
.4	Menu 'Recipe programming'	5 - 29
.5	Menu 'Recipe positioning'	5 - 34
5.4	MX08/2's device parameters	5 - 43
5.5	...an MX08/2 application example	5 - 49

Chapter 6: Trouble shooting

6.1 Fault avoidance 6 - 2
 6.2 Trouble shooting procedures 6 - 4

Chapter A: Appendix A

A.1 Overview: operating structure A - 2
 A.2 Description 'SIKONETZ protocol' A - 9
 A.3 Description 'standard protocol' A - 19
 A.4 Description 'FB protocol' A - 20
 A.5 Glossary: programmable parameters A - 21
 A.6 Summary data sheets for SIKONETZ devices A - 26

Chapter B: Appendix B

Angle- and Width-Violation-Monitoring System
 for Dornier TDO Streching Machines
 for Softwareversion **1.XX** of MX08/2 and AP03

Chapter C: Appendix C

Angle- and Width-Violation-Monitoring System
 for Dornier TDO Streching Machines
 for Softwareversion **2.0** of MX08/2 and AP03

Summary description

1

Setting up

2

Technical data

3

Function

4

Operation

5

Trouble shooting

6

**Appendix A
Appendix B
Appendix C**

**A
B
C**

1. Summary description

Contents:

1.1	SIKONETZ field-bus system	1- 2
1.2	Functions of the MX08/2	1- 4
1.3	... an MX08/2 application example	1- 6



1.1 SIKONETZ field-bus system

The SIKONETZ field-bus system is installed on machines / plant to

- record and display angles and distances of rotary or linear movements
- position axes with motorised adjustment systems

The SIKONETZ field-bus system consists of SIKONETZ devices, which are linked in the SIKONETZ field-bus system. Within the bus system the SIKONETZ control unit (master) is connected with a maximum of 31 SIKONETZ sub-stations (slaves).

The following SIKONETZ devices are presently available:

As master:

- multiplexing control MX08/2

As slaves:

- absolute encoders WK02, WK12, WK50, WK51
- incremental display MA08/3
- absolute display MA30
- incremental position display IG08/2
- absolute position display AP03
- intelligent actor IA08/2

The multiplexing control MX08/2 is designed to be a control unit within the SIKONETZ field-bus system. It allows controlling of the function of the SIKONETZ field-bus system. Via the MX08/2 the sub-stations (slaves) can be

- programmed
- controlled
- supervised.

Note !

For detailed information on the SIKONETZ field-bus system we refer you to the SIKONETZ compendium.

Appendix A includes summary data sheets for a quick reference on the presently available SIKONETZ devices.

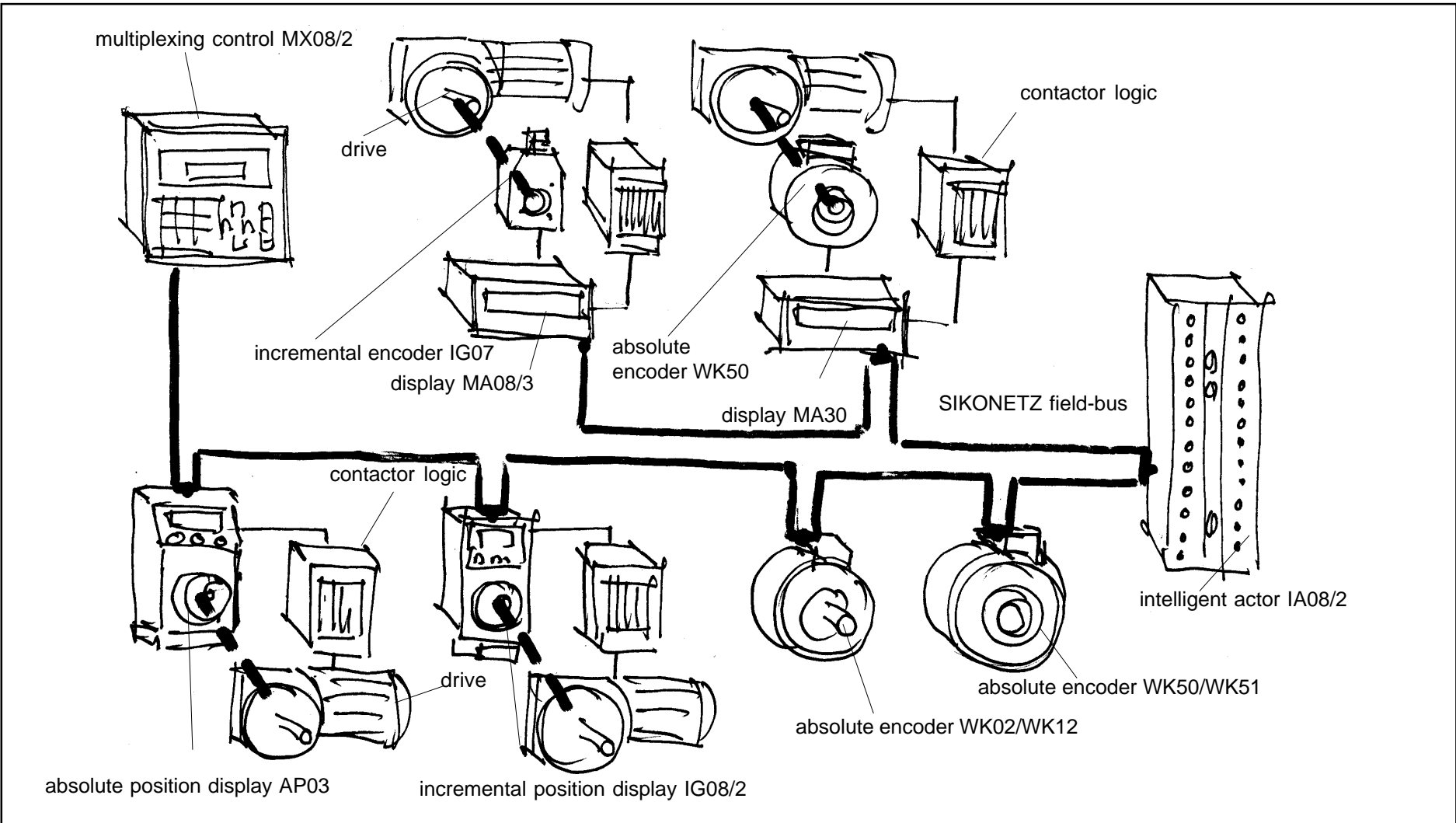

Fig. 1.1: SIKONETZ field-bus system

1.2 Functions of the MX08/2

The MX08/2 as control station offers two basic functions:

- controller function within the SIKONETZ field-bus system
- converter function; as SIKONETZ interface converter

Controller function

When used as SIKONETZ controller the SIKONETZ devices on the bus can be controlled via the MX08/2's keyboard and display.

You can

- program the SIKONETZ devices and adjust them to suit your application.
- display angles, distances and states captured by the SIKONETZ devices
- define target values for the positioning display devices on the SIKONETZ bus and supervise / control positioning

Converter function

When used as converter the MX08/2 acts as a bridge between the higher level control and the SIKONETZ field-bus system. Through the MX08/2 the control has access to the SIKONETZ devices and their function within the bus. The MX08/2 serves as interface converter between the SIKONETZ interface and the higher level control interface.

You can

- access from the main control all SIKONETZ devices and their functions
- supervise the application from the main control
- program the SIKONETZ devices at the first use directly from the MX08/2 and independently from the higher level control.

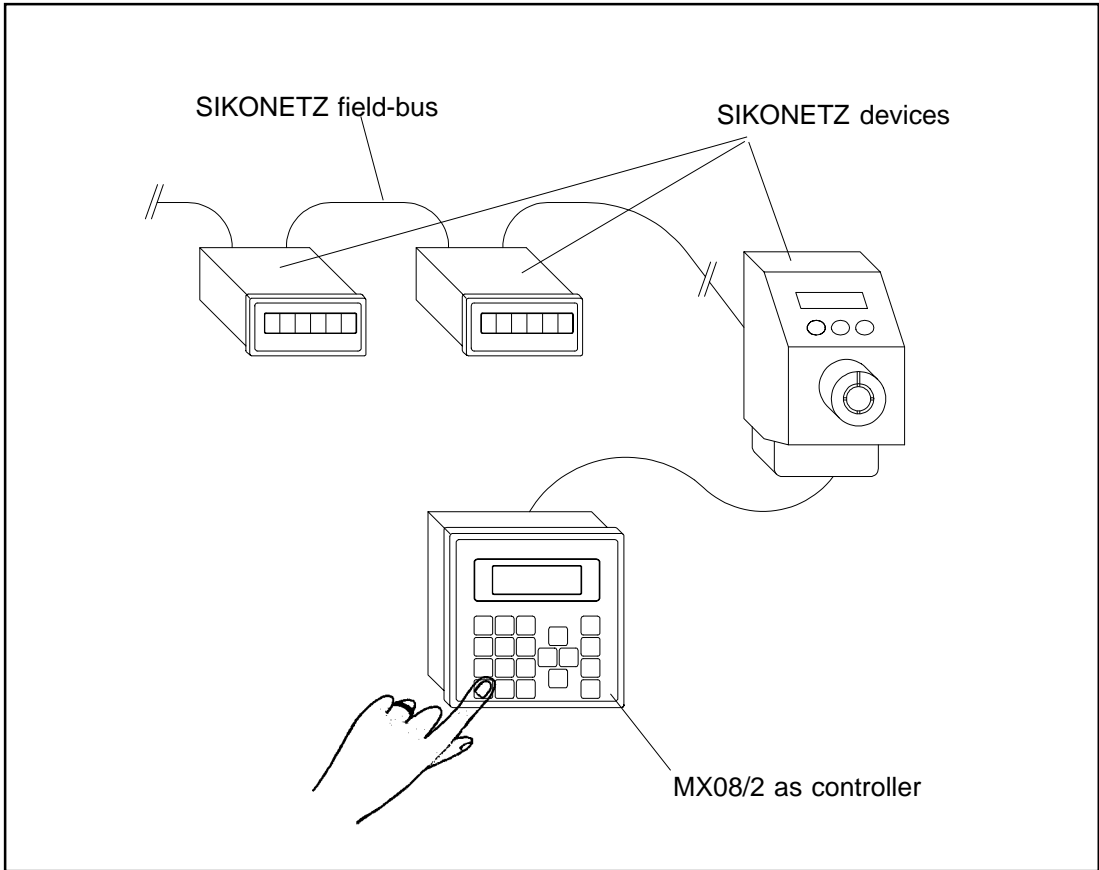

Fig. 1.2: MX08/2 as SIKONETZ controller

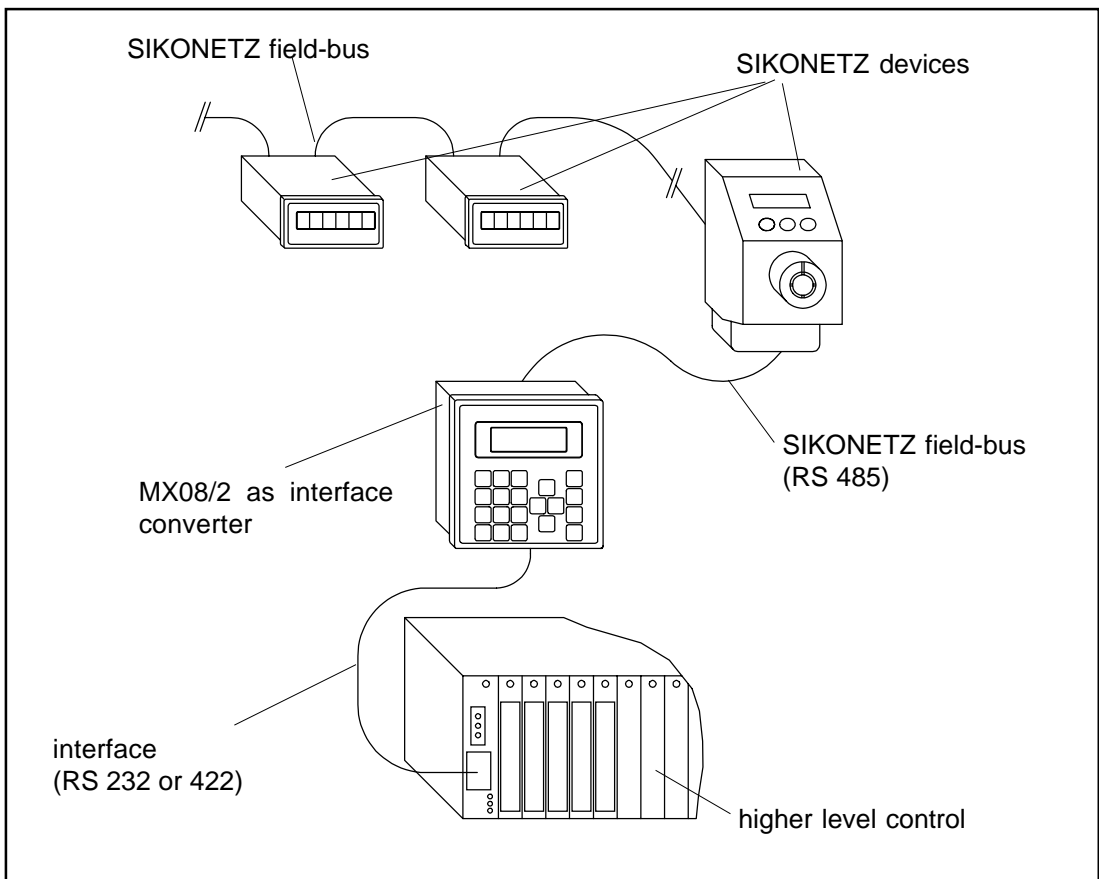

Fig. 1.3: MX08/2 as interface converter

1.3 ... an MX08/2 application example

The multiplexing control MX08/2 and six absolute position displays are used on plant which produces wood-chip boards to adjust the spread width.

At three stations wood chip is dosed on the conveyor belt. According to the final width of the wood-chip boards the spread width can be adjusted at each station by two motorised and independently working spindles. Each spindle is equipped with an AP03; the AP03 switching output triggers the corresponding motor.

All six AP03 units are linked with each other by the SIKONETZ field-bus system. The MX08/2 is mounted in the control panel in the machinist's cabin from where he is controlling and setting the width.

A later connection to a main control for automatic setting and production planning and control is planned.

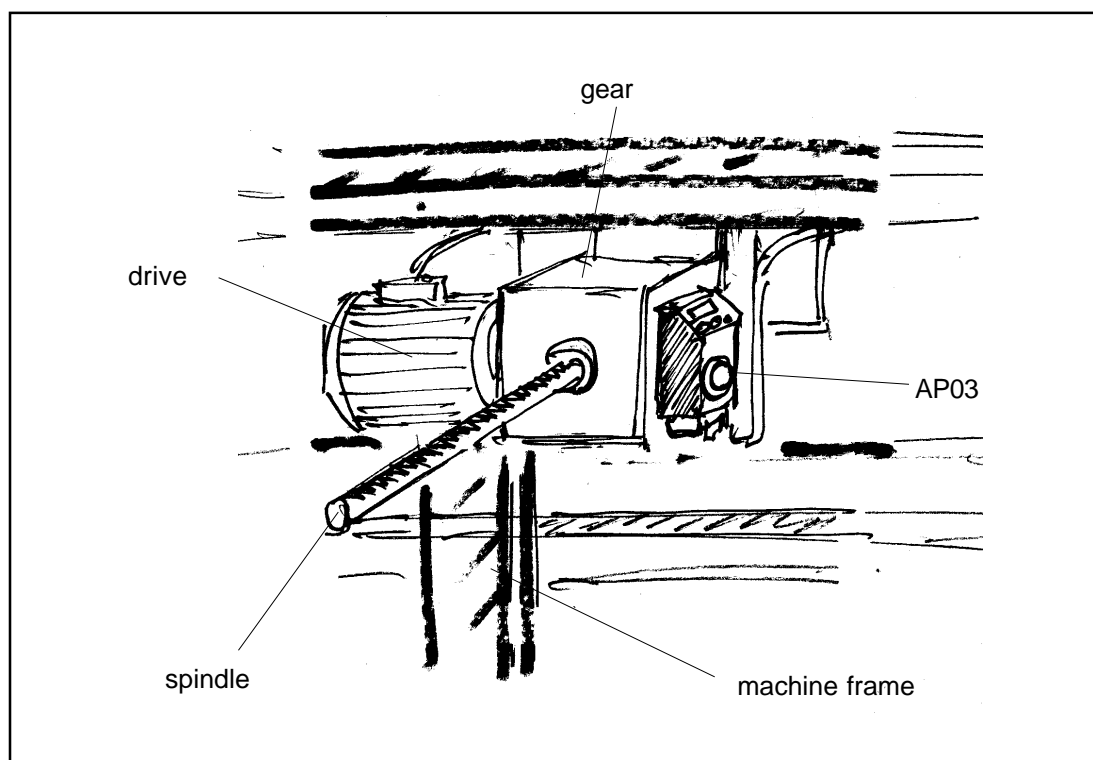

Fig. 1.4: Wood-chip board production; absolute position display AP03 mounted on a spindle to set the spread width

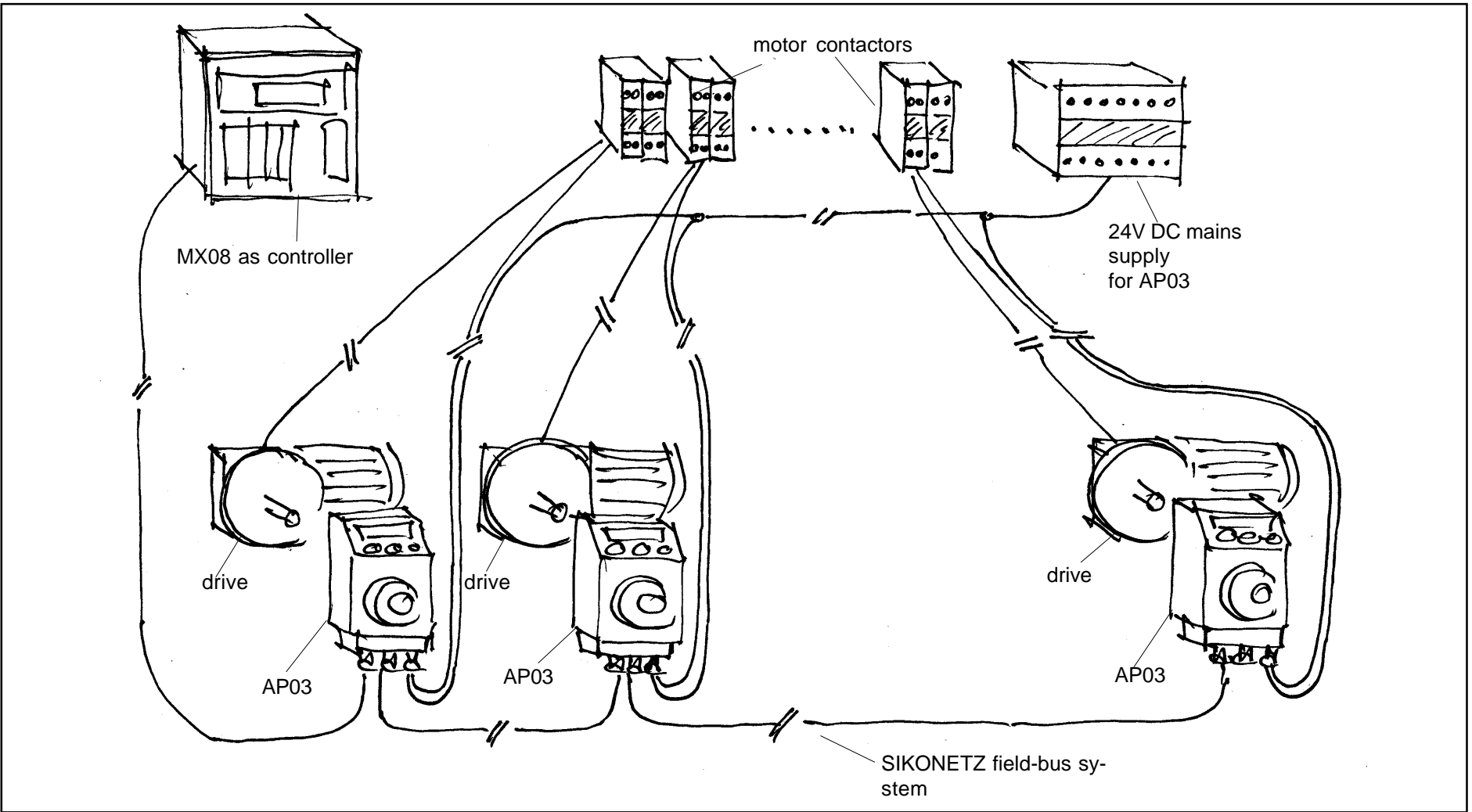

Fig. 1.5: Wood-chip board production, bock diagram of SIKONETZ- field-bus with MX08/2 and AP03

2. Setting up

Contents

2.1	General information and recommendation	2 - 2
2.2	Mechanical mounting, mounting/dismounting	2 - 4
2.3	Electrical mounting	2 - 5
2.4	Commissioning	2 - 7

Note!

To avoid trouble and annoyance we strongly recommend you proceed very meticulously when installing the SIKONETZ field-bus system. Above all please check the bus wiring before the first use of the SIKONETZ system. Any wrong wiring, short circuits or open leads will cause malfunction. In the chapter 'Fault finding' you will find further information and checklists, which we recommend you study and use before the first running of the system.

2.1 General information and recommendations

... on the mounting place

When mounting the MX08/2 please respect the following points:

- IP protection class

The MX08/2's protection class according to DIN/VDE must comply with the environmental conditions at the mounting place.

- Condensation

High residual humidity (> 95% rF) or condensation is not permitted. Provide for adequate ventilation and temperature equalization.

- Temperature

Respect the MX08/2's admissible operating temperature range. Especially in case of very confined mounting, you should provide for ventilation to avoid local overheating of the MX08/2.

- Panel cut-out

Must be according to DIN 43 700.

- Special protection

May become necessary in case of extreme influences at the mounting place. If necessary the MX08/2 must be additionally protected.

... on electrical safety

Please respect the safety regulations, standards and stipulations from DIN, VDE and employer's liability insurance associations. These regulations were created for your own and other people's safety!

The general rules regarding setup, commissioning and operation of electrical devices are closely linked with a reliable functioning of the SIKONETZ field-bus system.

Especially:

- Disconnect any power before plugs or screw terminals are removed!
- Disconnect before you start any wiring work!
- Carefully check all connectors, cables and the running of the wiring before the first use of the system!
- Provide stranded wires with ferrules!

... on interference

All connections of the MX08/2 are widely protected against the effects of interference. The location of the MX08/2 should be selected to ensure that external signals cannot affect the connectors and/or incoming/outgoing connection lines either galvanatically or inductively and/or capacitively.

In most cases interference comes from motors, switch gear, cyclic controls or contactors and their corresponding cables. Although, by positioning the MX08/2 well away from these units and by suitable wiring layout, interference cannot be totally avoided, it can be minimised, so that there is no more negative effect on the function of the MX08/2.

Disturbance due to electro-magnetic interference (EMI) has its own rules. In theory the reasons for this kind of disturbance is known, but in practice things might be different. If necessary we recommend you make field tests and take steps for additional interference reduction in order to reduce interference to a degree, where it no longer influences the function of the MX08/2.

Sometimes interference may also be caused by compensating currents due to potential differences; these can only be eliminated by a comprehensive potential equalization concept or by galvanic separation. As inputs and outputs of the MX08/2 and the SIKONETZ field-bus system are equipped with opto-electronic couplers, interference can be widely suppressed by galvanic separation.

Basically the following measures are necessary / recommended:

- Only screened cable should be used. In order to avoid high frequency interference, provide for short and large surface area (low resistance) connection of the screen. Most disturbances result from high-frequency interference. Whether the screen should be connected to ground on one or two sides depends on your application and the mounting position; if necessary, we recommend you perform a test.
- Wiring to the screen and the ground (GND, 0 V) must be secured to a good point and a large surface area.
- Wiring cross-section is to be at least 0,14 mm².
- The running of the MX08/2 wiring parallel to the mains supply or to noise sources should be avoided. Keep distance as far as possible. Cross such lines vertically.
- The MX08/2 should be positioned well away from noise sources (lines). If necessary, a protective screen or metal housing must be provided.

2.2 Mechanical installation, mounting/dismounting

Check whether the panel cut-out for the MX08/2 corresponds to the DIN 43 700 standard.

Mounting of the MX08/2 should be made in 3 steps (see below):

- Push the MX08/2 into the panel cut-out (C) until the panel clips (A) hold the housing loosely.
- Press the lateral centering (B) slightly down and push the housing into the cut-out (C), until the MX08/2's frontal frame is approx. 10 mm from the panel cut-out.
- Push the MX08/2 into the cut-out, until the panel clips (A) snap completely.

For dismounting the MX08/2, use a suitable tool to either lift it laterally out of the panel or simply push it from the rear.

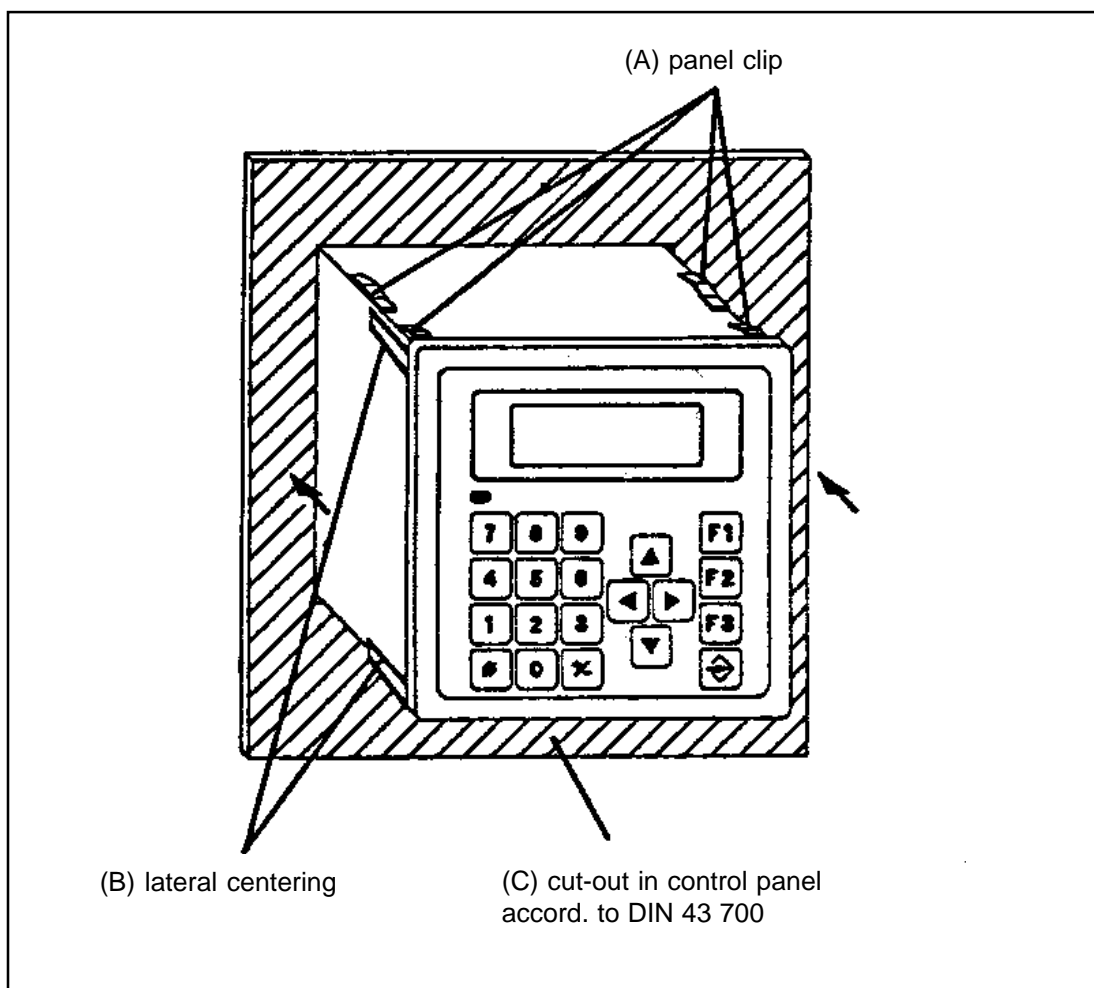

Fig. 2.1: MX08/2 panel mounting according to DIN 43 700

2.3 Electrical installation

Switch off power before you carry out the electrical connection. Provide stranded wires with ferrules. Screen connection should be made as short as possible and at the suitable pins.

Connection / pins

1	input switch 'S _{ext} '	14	GND, (shielding RS232, RS 422)
2	GND switch 'S _{ext} '	15	N.C. (RS232); TXD-A (RS422)
3	not connected	16	N.C. (RS232); TXD-B (RS422)
4	not connected	17	TXD (RS232); RXD-A (RS422)
5	not connected	18	RXD (RS232); RXD-B (RS422)
6	not connected	19	GND, (ground RS232, RS422)
7	not connected	20	GND, (shielding RS485 SIKONETZ)
8	not connected	21	not connected
9	not connected	22	not connected
10	not connected	23	DÜA, (RS485 SIKONETZ)
11	not connected	24	DÜB, (RS485 SIKONETZ)
12	not connected	25	GND, (ground RS485 SIKONETZ)

Table 2.1: Pin connections of MX08/2 (standard type)

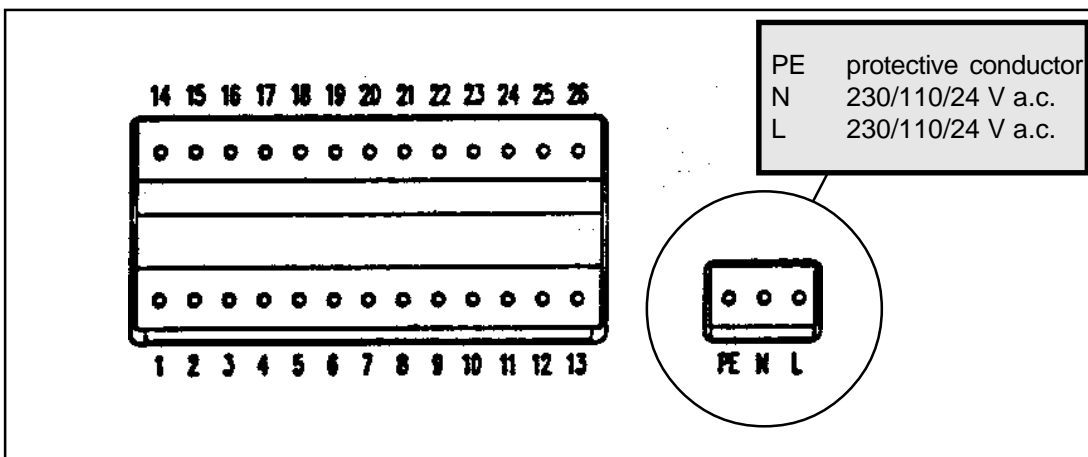

Fig. 2.2: MX08/2 terminal strip, rear view

Information on pin connections:

- Switch 'S_{ext}', which can also be positioned outside the MX08/2, is used to change the access right during 'Setting mode' and 'Operating mode'. For detailed information, please read chapter 'Access rights'.
- When ordering the MX08/2 the electronic interface to the main control should be specified (RS232 or RS422). Pin connection is to be made in accordance with the interface. The supplied interface type, can be seen from the ordering code.



2.4 Commissioning

Please proceed as follows:

- Unpack the MX08/2. Check it for possible transport damage. Check the type mentioned on the identification plate and the type confirmed in the order confirmation.
- Disconnect any power from your plant. Connect the enclosed plugs. Connect mains lines and the lines of the SIKONETZ field-bus system. Do not yet connect the interface to the main control and the input for switch 'S_{ext}'.
ext
- Please use the overleaf checklist to ensure a troublefree commissioning of the system.
- Deactivate all drives, which are triggered by SIKONETZ devices, eg. by taking the drive fuses out of the electric circuit.
- Mount the MX08/2 at the assigned place. Depending on the mounting situation, plug in at the rear of the MX08/2 before or after mounting. Switch off power before!
- Now switch on the SIKONETZ plant. The MX08/2 displays the switch-on sequence (see also point 4.5 'When switched on').
- The MX08/2 displays main menu point 'Menu choice' and is ready for use. You can now start working with the connected devices.
- Program the MX08/2's and the SIKONETZ-device's parameters.
- If SIKONETZ devices are used to trigger drives, you can now gradually start activating axis positioning (eg. by activating the drive fuses again). Use stepping mode to test positioning.
- The interface connection to the main control can now be put to work. Switch off the plant before you connect the additional attachment plug.
- Use the switches 'S_{int}' or 'S_{ext}' (to be provided by you) to determine the access rights (see also chapter 5.2 - Access rights).
int ext

Checklist:

- Voltage supply: correct type (AC, DC) ?
- Voltage supply: correct voltage (230, 110, 24 V) ?
- Have the voltage tolerances been respected ?
- Is switch 'S_{int}' open (and thus open access to the device's parameters) ?
- Did you check the field-bus wiring ?
- Are all devices connected to the field-bus system?
- Are the field-bus signals DÜA and DÜB always correctly connected ?
- Is the common signal ground on both sides connected ?
- Screening of the field-bus wiring on both sides connected ?
- Short-circuit check carried out ?
- Got the SIKONETZ devices correct addresses ?
- Is the voltage supply for all other SIKONETZ devices correct?
- Is this voltage switched on simultaneously with the MX08/2's voltage supply ?

3. Technical Data

Contents

3.1	Identification plate, identification key	3 - 2
3.2	Technical data	3 - 3
3.3	Connection	3 - 4
3.4	Dimensions	3 - 5

3.1 Identification plate, identification key

Identification plate

Equipment description and variant code are contained in the type designation on the identification plate. The variant code is computer-generated and allows a correct identification of the MX08/2's features. In the event of a query, please provide equipment description and serial number from the identification plate.

Please check particular type of unit from our delivery documentation.

Identification key

MX08/2 - XXXX

Multiplexing control type MX08/2

	Key	Choice/Description
Interface I	: XX	S1 = RS232, S2 = RS422
Interface II / protocol	: XX/XX	S3/01 = RS485/SIKONETZ
Digital inputs	: X	0 = without (standard), 1 = with
Digital outputs	: X	0 = without (standard), 1 = with
Electrical connection	: E1	E1 = 26-pole and 3-pole terminal strip
Supply voltage	: X	1 = 230 V a.c., 2 = 110 V a.c., 3 = 24 V a.c.
In case of special designs:		
Special type	: XX	Description enclosed
Configuration	: XXX	See enclosed configuration sheet

Explanation:

Interface I: interface for a master computer or higher level control.

Interface II: interface for connection of the SIKONETZ field-bus system.

The standard type of MX08/2 has no digital inputs/outputs. Special types can be supplied with digital inputs/outputs assuming various functions. Please inquire at SIKO and/or read the information in appendix B on customer-specific assignment.

3.3 Terminal strip connection

Pin connection

1	input switch 'S _{ext} '	14	GND, (shielding RS232, RS 422)
2	GND switch 'S _{ext} '	15	N.C. (RS232); TXD-A (RS422)
3	N.C. (not connected)	16	N.C. (RS232); TXD-B (RS422)
4	N.C.	17	TXD (RS232); RXD-A (RS422)
5	N.C.	18	RXD (RS232); RXD-B (RS422)
6	N.C.	19	GND, (ground RS232, RS422)
7	N.C.	20	GND, (shielding RS485 SIKONETZ)
8	N.C.	21	N.C.
9	N.C.	22	N.C.
10	N.C.	23	DÜA, (RS485 SIKONETZ)
11	N.C.	24	DÜB, (RS485 SIKONETZ)
12	N.C.	25	GND, (ground RS485 SIKONETZ)

Table. 3.1: Terminal strip MX08/2 , standard type

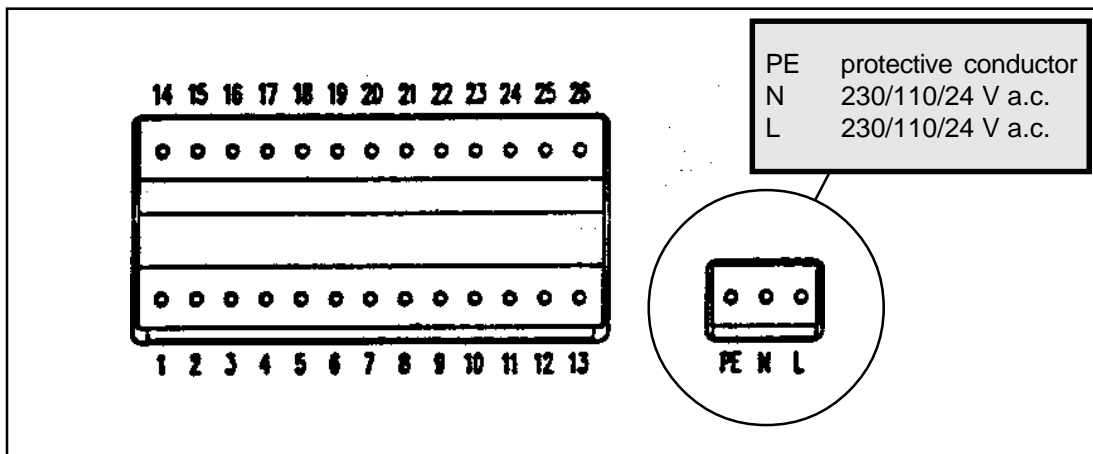

Fig. 3.2: Terminal strip MX08/2, rear view of device

Explanation

- Switch 'S_{ext}', which can also be positioned outside the MX08/2, is used to change the access right during 'Setting mode' and 'Operating mode'. For detailed information, please read chapter 'Access rights'.
- When ordering the MX08/2, the electronic interface to the higher level control should be specified (RS232 or RS422). Pin connection of pins 14 to 19 is to be made in accordance with the interface. The interface type supplied can be seen from the ordering code.

3.4 Dimensions

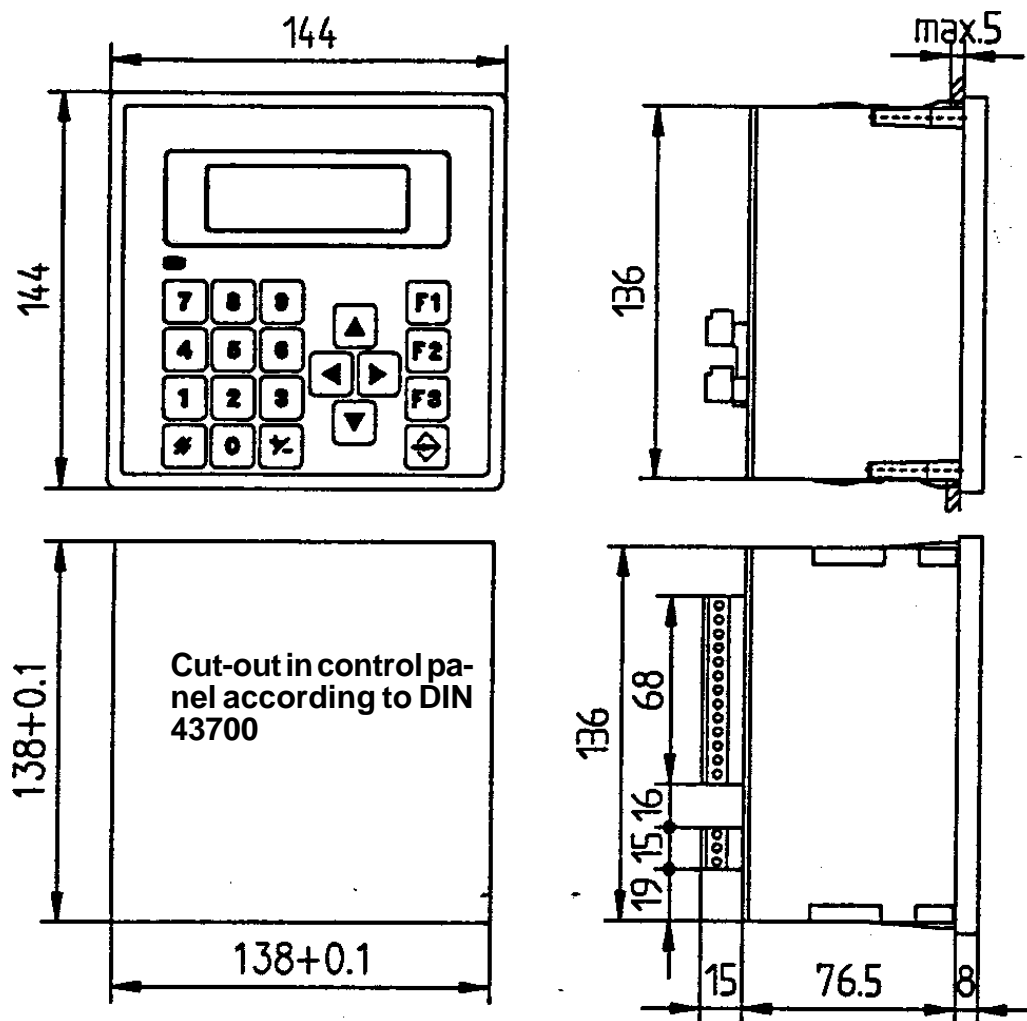

Fig. 3.3: Dimensions

4. Function

Contents

4.1	Set up and block diagram	4 - 2
4.2	Significance within the SIKONETZ field-bus system	4 - 3
4.3	Interaction with other SIKONETZ devices	4 - 3
4.4	Interaction with a central control	4 - 4
4.5	MX08/2 as interface converter	4 - 5
4.5	When switched on	4 - 7
4.6	Address setting within the SIKONETZ field-bus system	4 - 9

4.1 Set up and block diagram

The MX08/2's hardware includes:

- microprocessor with program memory
- display
- keyboard
- power supply
- battery-backed data memory
- interface I to higher level control
- interface II to SIKONETZ system

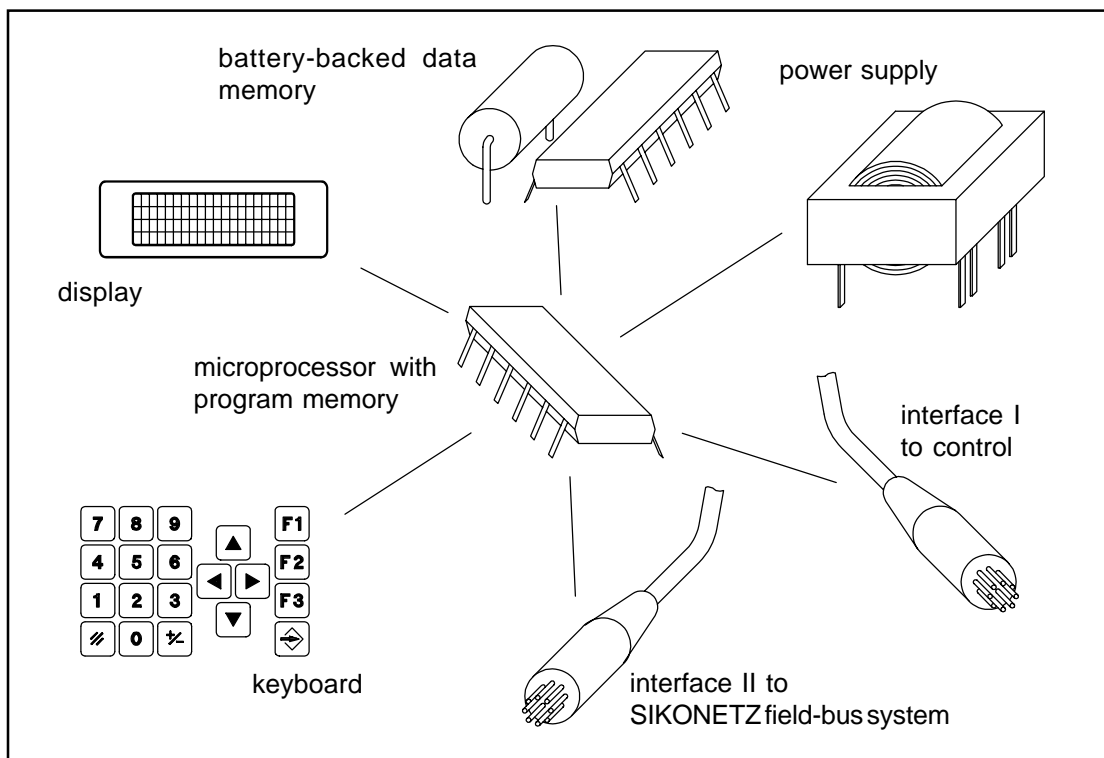

Fig. 4.1: MX08/2's hardware components

4.2 Significance within the SIKONETZ field-bus system

The MX08/2 is the master station of the SIKONETZ field-bus system. Its software and hardware has been especially designed for use with SIKONETZ devices.

The SIKONETZ field-bus system can be run with one master station only. Hence you can only use one MX08/2 in your application. All other devices must be used as sub-stations (slaves).

As master station, the MX08/2 determines all bus activity. All other devices (slaves) may only respond to the MX08/2's commands.

This master/slave principle is for most applications no restriction. It simplifies system operation, fault finding and especially the software of the devices and higher level control. This maintains a high degree of reliability in application.

4.3 Interaction with other SIKONETZ devices

The MX08/2 uses the SIKONETZ field-bus' command / answer system to offer you a variety of functions for the devices used as slave stations. The display of the MX08/2 shows values and messages on the state of the sub-stations. Via the keyboard you can select functions, start or stop positioning, ie. completely control/supervise your application/machine from the MX08/2.

Each action is based on commands / messages between the MX08/2 and the addressed slaves. Types and number of commands which a slave station can understand and reply to, as well as the corresponding functions, are slave unit specific.

Note !

The basic functional principle and an overview of the unit specific commands and messages are described in the SIKONETZ compendium. Please enquire, if you did not receive it together with the MX08/2 manual. Appendix A includes summary data sheet for a quick reference on the suitable SIKONETZ devices and on the unit-specific functions.

4.4 Interaction with a central control

There are two possibilities to supervise a SIKONETZ application from a high level control:

- To connect the SIKONETZ- field-bus and the SIKONETZ data format directly to the central control without using the multiplexing control MX08/2. All relevant information is given in the SIKONETZ compendium.
- To indirectly connect the SIKONETZ field-bus by using the MX08/2 as interface converter. The underlying technology is described below.

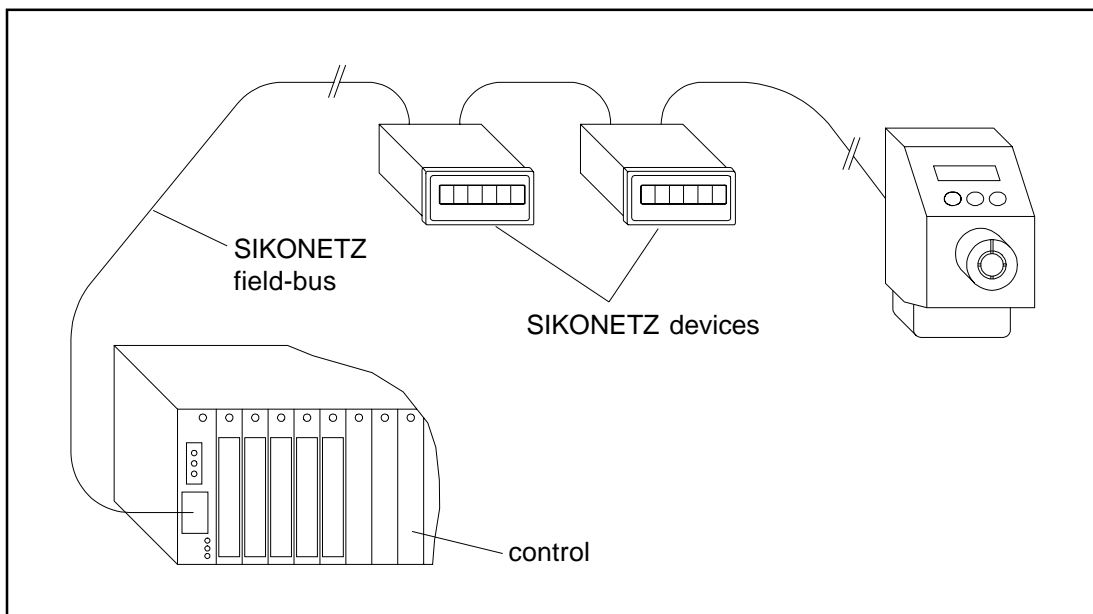

Fig.4.2: Direct connection, control/SIKONETZ

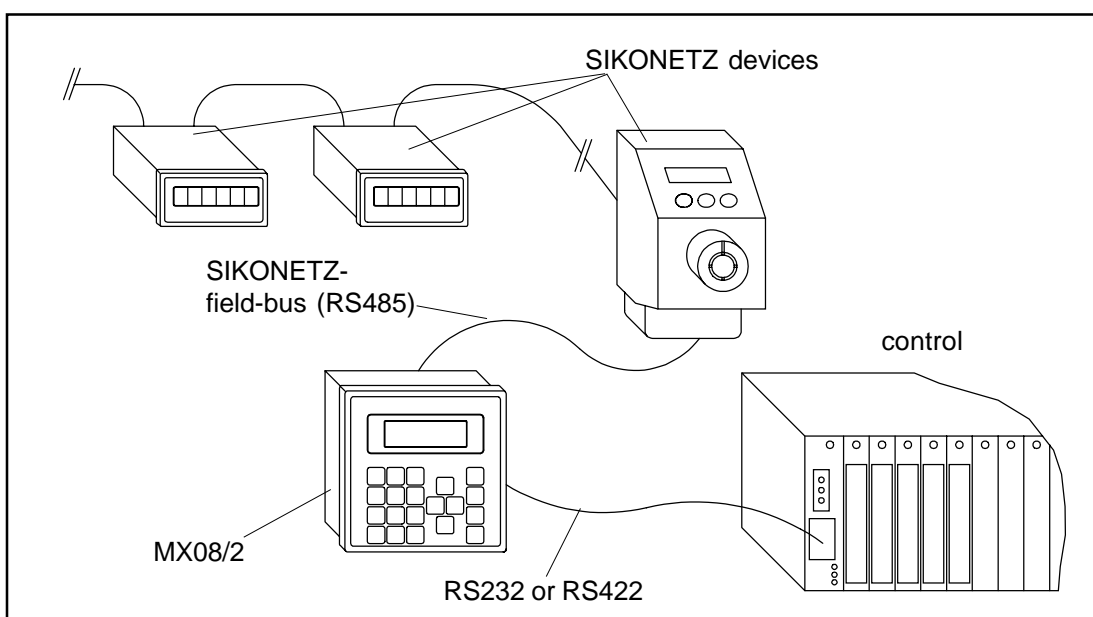

Fig. 4.3: Indirect connection, control/MX08/2/SIKONETZ

4.5 MX08/2 as interface converter

Overview:

As interface converter the MX08/2 assumes four functions:

- To adapt the electrical properties of two interfaces
(interface I: SIKONETZ RS485 <—> interface II: RS 232 or RS422)
- To adapt the baud rates
(SIKONETZ 19200 baud <—> baud rate selected by customer)
- To adapt the SIKONETZ data format consisting of 9 bits to standard customer data format consisting of 8 bits.
- To adapt the protocol and the data's significance

Presently you can choose between 2 data transmission protocols on interface I between MX08/2 and main control:

- 'standard' protocol
- 'FB' protocol

Protocol and baud rate are determined when programming the MX08/2's parameters. Programming is described in chapter 5.4 'MX08/2's device parameters'.

'Standard' protocol (see also data sheet in appendix A)

In this case, which is the easiest one, communication protocol and data message are only slightly modified. The MX08/2 only adapts electrical interfaces, data length and baud rate. From the view of the main control and the slave stations the MX08/2 behaves totally transparent as data contents are not changed. The control operates as master station and replaces the MX08/2.

For this purpose the control's software must be able to assume the tasks of a SIKONETZ master station. Free access to SIKONETZ commands/messages enables the user to adapt / optimize his software.

'FB' protocol (see also data sheet in appendix A)

In this case the structure of the SIKONETZ protocol also remains unchanged. Data information included in commands and messages is taken over. The time-consuming but secure CRC-check (Cyclic redundancy check = error-free transmission check) is replaced by a more simple but quicker check with parity bit and block parity. The 'FB' protocol allows connection of the SIKONETZ field-bus system to Siemens S5-controls.

Note!

SIKO offers for the protocol 'FB' function modules for the transfer of software between Siemens S5 and the SIKONETZ control unit. These function modules considerably simplify the connection of the SIKONETZ field-bus system with MX08/2 as interface converter to a S5-control.

Functional description:

When started up, switched on and after successful scanning the bus system for sub-stations, the MX08/2 is in normal state and displays main menu. In this menu state the MX08/2 also operates as interface converter.

If the MX08/2 receives in this menu state messages from the main control, these commands are converted and passed on to the SIKONETZ field-bus. Messages coming from a slave units are also converted and then transmitted to the main control.

Details on chronological sequences of data transmission, data format and signification are given in appendix A.2.

When used together with a main control, the MX08/2 can also be operated as controller unit (see below). This allows control of the SIKONETZ-field bus directly from the MX08/2. Select one function in main menu and confirm it with 'Enter'; the MX08/2 interrupts converter mode and the SIKONETZ field-bus system can be controlled via the MX08/2's display and keyboard. If the MX08/2 receives in this menu state messages from the main control, it issues an error message from which the control can see that the MX08/2 is presently working as controller.

Only after returning to main menu (press key F3, if necessary repeatedly), the MX08/2 continues in interface converter mode.

Application information:

Even in applications where the field-bus could normally be directly connected to the main control, the MX08/2 offers the following advantages:

- Reduced programming work on side of the main control:

For an initial and future setting/programming of the slave units, the MX08/2 can be used as controller. Hence the main control need not be equipped with a special setting software, but with operating software only.

- Immediate availability:

The MX08/2 allows you to adjust and test your machine / plant already at a time when control or special software are not yet available.

- Emergency service, fault localization:

If the main control fails, the MX08/2 can be used for a local emergency operation. After disconnecting the higher level control ,the MX08/2 can carry out fault localization to find out whether the fault is coming from the higher level control or from the SIKONETZ field-bus system.

4.5 When switched on

When switched on, the MX08/2 passes the following steps:

- a) Hardware and microcontroller reset
- b) Self-test and setup of the internal data store
- c) First message display
- d) Waiting loop of approx. 2 seconds without any activity
- e) Start and display of slave unit scanning
- f) Scanning of the SIKONETZ field-bus for slave units.
- g) Identification of the units found and their registration in an 'existence' list
- h) Depending on the scanning result, an error message is issued:
'No slave unit found' or display of main menu and ready for operation.

Additional information:

- Steps a) to c) are internal processes inside the MX08/2.
- Step d) secures a faultless start of the SIKONETZ field-bus system. The break enables the slave units to complete their internal starting process; now they are ready for use. The subsequent scanning of the MX08/2 for slave units can only be successful, if they are ready for operation.
- Steps e) to g) enable the MX08/2 to find out, which devices are connected to the field-bus. Starting with address 1 the MX08/2 scans all addresses up to 31. It sends to each address a message asking for identification of the connected slave unit.

If, under the transmitted address, no device is connected, no reply will be returned. The MX08/2 waits some time for the reply and if no reply is sent, 'No slave unit found' will be entered into the 'existence' list.

If, under the transmitted address, a device is found, it will issue an identification message from which it can be identified by the MX08/2. The slave unit's identification code is registered in the MX08/2's 'existence' list.

When all addresses have been scanned, the MX08/2 disposed of an internal list showing the structure of your SIKONETZ field-bus system. This list can be used to select the different slave units and their corresponding menus.

During starting and scanning process for connected slave unit, the MX08/2 displays two messages:

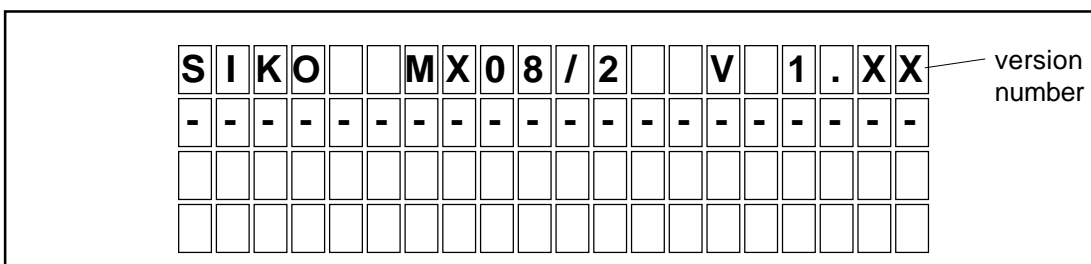

Fig. 4.4: Display after starting

The first message shows the MX08/2's current software version. The version is displayed in the form of three numbers. The first digit before the point stands for the main version. The two numbers after the point (in the above example 'XX' for any possible numbers) signal the update version. The title of this manual informs about its underlying update version number.

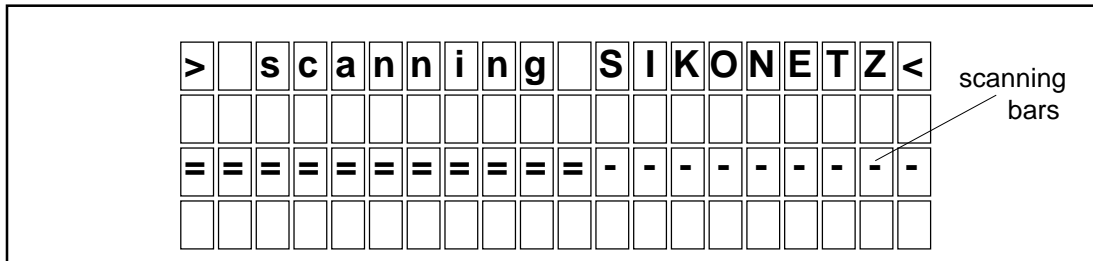

Fig. 4.5: Display during scanning of the SIKONETZ field-bus for slave units

Fig. 4.5 shows the display during SIKONETZ field-bus scanning for connected SIKONETZ-devices. The third line first displays bars. The double bars on the left signal that the MX08/2 has started scanning the SIKONETZ field-bus.

If the search (scan) has been successful, the MX08/2 displays the main menu:

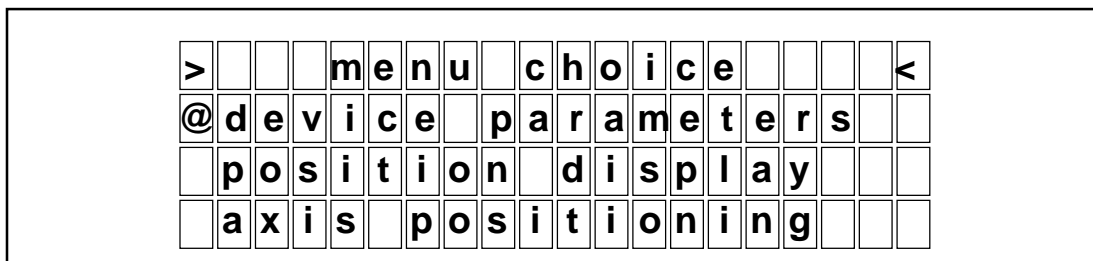

Fig. 4.6: Main menu

If the search (scan) has not been successful because the MX08/2 did not find any SIKONETZ-devices, an error message is displayed:

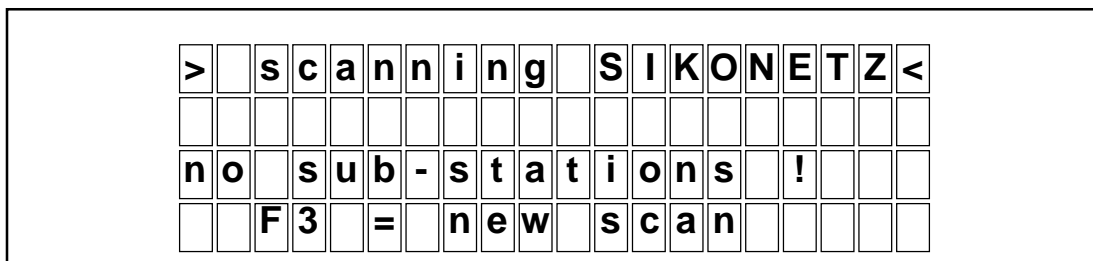

Fig. 4.7: Error message after unsuccessful search (scan) of the SIKONETZ field-bus

In this case use key F3 to repeat scanning. But in any case we recommend to read chapter 6 = Fault finding as such an error should never occur on an already working machine and during the initial setup. It signals that there is a fundamental mistake in the setup of the system. Please use chapter 'Fault finding' for error diagnostic!

4.6 Address setting within the SIKONETZ field-bus system

Apart from the multiplexing controller MX08/2, up to 31 sub-stations can be connected to the SIKONETZ field-bus, ie. 32 devices altogether. For correct identification each device on the SIKONETZ field-bus has its own address, which can be set to any from 1 to 31. Each address may only occur once on the bus.

Address 0 belongs to the MX08/2 controller. Generally this is fixed and cannot be changed. The remaining 31 addresses from 1 to 31 are for the SIKONETZ-devices working as slave units within the system.

You should already allocate the sub-stations's addresses when planing and setting up the SIKONETZ application. The addresses 1 to 31 can be freely allocated. Nevertheless you should proceed systematically to facilitate your work. Most address patterns result from the application's specific setup.

Before you can operate the SIKONETZ, the devices must be set to the desired address. Unless there has been special instruction, all devices are preset at the factory to the address 0. Address setting is different for each device and described in the device-specific documentation accompanying each unit.

Points,

... you should respect during address setting on slave units:

- Each address may only occur once on the bus.

If one address is used for different devices, this will lead to errors, as several devices will simultaneously reply to the MX08/2's commands. Each of these devices responds to commands from the MX08/2. In case of identical addresses the devices' replies will overlap and cannot correctly or not at all be read by the master station.

- The address must not be 0.

The address 0 must not be used for SIKONETZ-devices working as slave units. This address is reserved for the master station MX08/2.

- The address must range between 1 and 31 (inclusive).

Addresses beyond 31 cannot be addressed as they are not within the defined address range.

Recommendations

... for address allocation of the slave units:

- Address allocation can start with any value from 1 to 31.

If, from the setup of your machine, it is suitable to start with another address than 1 (perhaps your machine is only equipped from the 5th axis with SIKONETZ-devices and you want to allocate the addresses according to the axis succession) you can skip the addresses 1 to 4.

- Address allocation need not be consecutive.

In case of several slaves, they need not have consecutive addresses. The address number can be chosen in accordance with your application (eg. 10,11,12, 20,21,22).

Checklist

... for correct address allocation:

- Is there a master station ? (MX08/2)
- Does it have the address 0 ? (if the master is a MX08/2, it will have automatically address 0)
- Is there no additional central control ?
- Is there at least one slave unit ?
- Are there max. 31 slave units ?
- Do the addresses of the slave units range from 1 to 31 ?
- Has each address only once been allocated (if at all)?
- Did you switch off and on the corresponding device after an address change in order to activate the new address ?

Note!

Please register in the following list the allocated addresses, the corresponding device designation and the mounting place. Moreover we recommend you make a schematic drawing from which mounting place, unit type and its address as well as wiring of on the SIKONETZ field-bus can be seen. This facilitates repairs/replacements on the bus-system.

Address list of the SIKONETZ field-bus system

(application description/place/author/date)

Address	Type	Designation	Function	Mounting place
0				
1				
2				
3				
4				
5				
6				
7				
8				
9				
10				
11				
12				
13				
14				
15				
16				
17				
18				
19				
20				
21				
22				
23				
24				
25				
26				
27				
28				
29				
30				
31				

Drawing SIKONETZ field-bus application

(application description/place/author/date)



5. Operation

Contents

5.1	Operating elements	5 - 2
.1	Keyboard	5 - 3
.2	Keyboard table	5 - 4
.3	Display	5 - 5
.4	Display of long lists via cursor	5 - 6
5.2	Access rights	5 - 7
5.3	Main menu	5 - 13
.1	Menu 'Devices' parameters'	5 - 15
.2	Menu 'Position display'	5 - 20
.3	Menu 'Axis positioning'	5 - 27
.4	Menu 'Recipe programming'	5 - 29
.5	Menu 'Recipe positioning'	5 - 34
5.4	MX08/2's device parameters	5 - 43
5.5	...an MX08/2 application example	5 - 49

Note!

You should study this chapter if you want to become familiar with the operation of the MX08/2. If you already know the MX08/2 and you only want to refresh your knowledge, read the summary survey in Appendix A.

5.1 Operating elements

Overview

The MX08/2 is operated:

- with the front keyboard, where values are entered.
- with the front display, where values and messages are displayed.

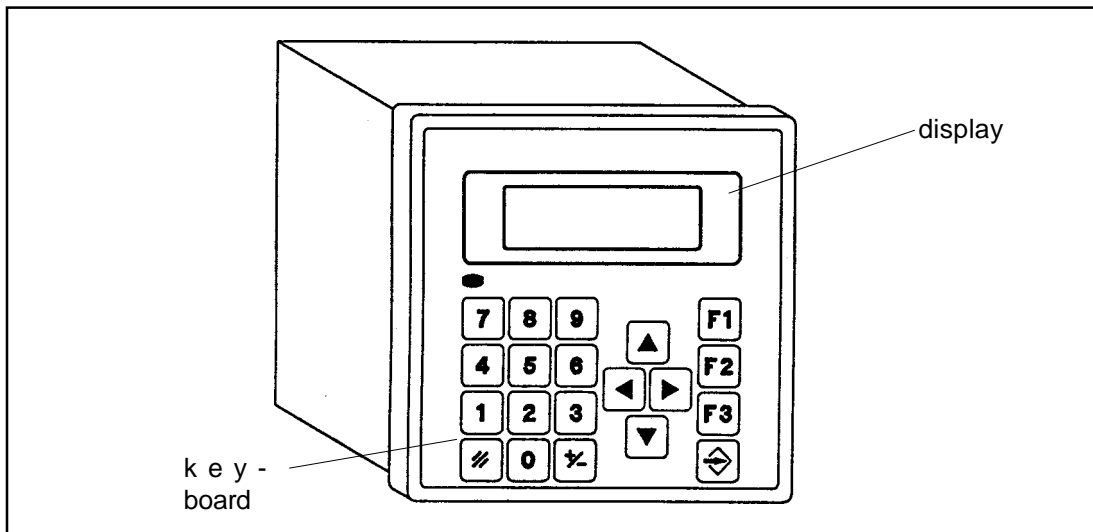

Fig. 5.1: MX08/2's front operating elements: keyboard and display

Apart from these operating elements, there are on the MX08/2's rear switches for access rights control.

5.1.1 Keyboard

The keyboard contains 3 blocks:

- numerical keyboard
- arrow keys
- control area

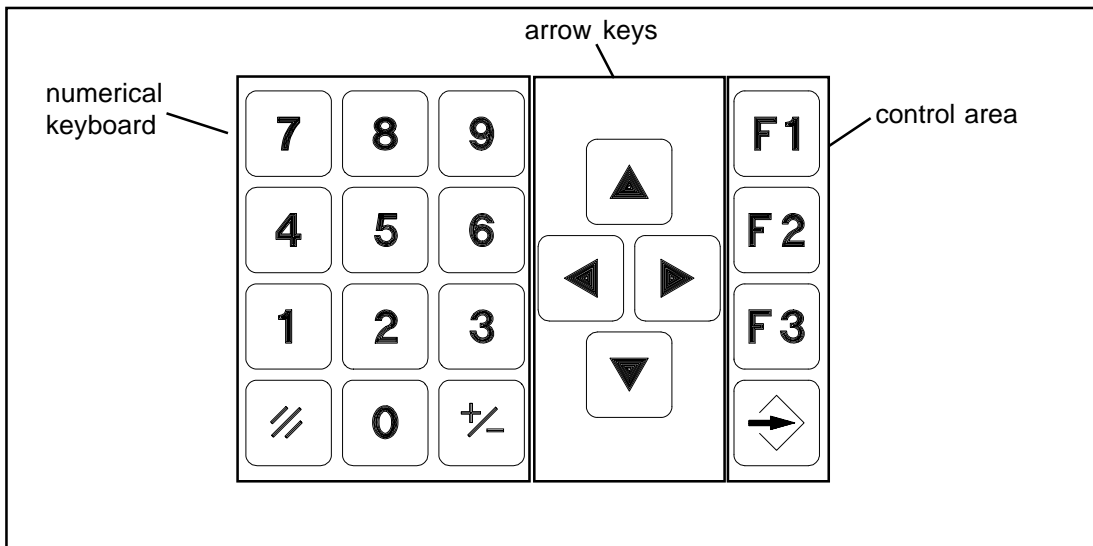

Fig. 5.3: Keyboard elements and keyboard blocks

- Numerical keyboard:

To enter numerical values; to change sign of a value and to delete input values.

- Arrow keys:

To select line / column . Press either of the arrow keys to shift the cursor within the display.

- Control area:

To trigger operating functions for machine operation (eg. sub-menu selection).

5.1.2 Keyboard table













Key (symbol)	Main function(s) of the key(s)
 ... 	Digit: to enter digits 0 to 9
	Sign: to change the sign
	Delete: to delete input
   	Arrow keys: to shift the cursor
	Function key F1: 'Help'-menus
	Function key F2: to start
	Function key F3: to stop , to return to previous menu
	Enter key: to store, to pass to the next menu

Table. 5.1 : Keyboard elements and their function

Explanation:

As long as key F1 is pushed, a 'help' text giving information on the present operating situation is displayed. As soon as key F1 is released, the previous display is monitored again.

All other keys need only be pushed once.

5.1.3 Display

Display consists of 4 lines, each with 20 columns (digits).

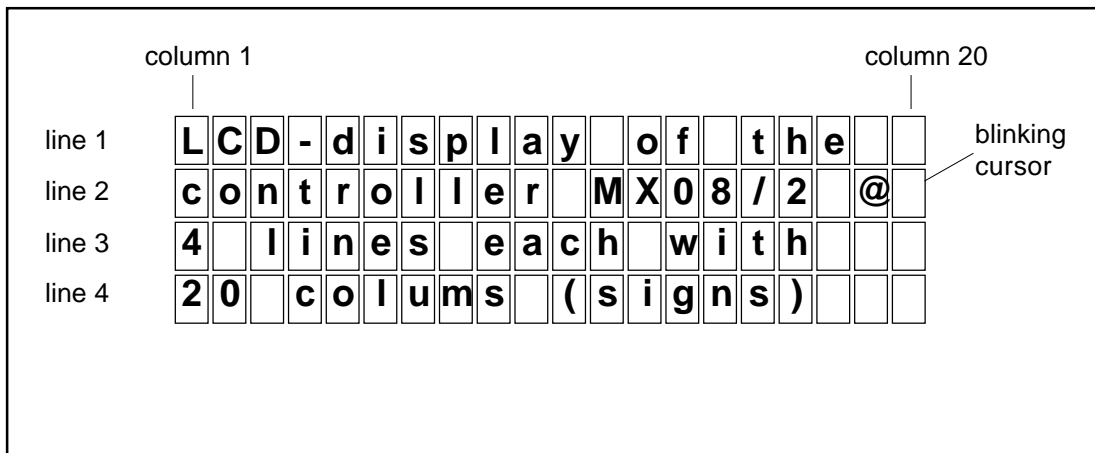

Fig. 5.4: Display elements

- Line 1 primarily displays the main functions.
- Display of line 2 to 4 depends on the selected main function.

Blinking cursor (position marker) has two functions:

- Marks the digit where the next value will be entered.
- Marks a line, when a menu point has been selected from a menu point list.

5.1.4 Display of long lists via cursor

Sometimes, eg. when a long list is to be displayed, 4 lines may not be sufficient. In this case only part of the list will be shown.

This happens for example:

- with main menu list, if more than 3 operating functions are displayed for programming
- with devices' parameter lists
- with position value lists, if more than 3 devices are connected to the SIKONETZ field-bus

Use cursor keys for scrolling.

Push arrow keys 'Up' / 'Down' repeatedly, until the cursor reaches the last / first line. Then push arrow key again; the cursor will stay in the last / first line and a new line will be added below / above. All other lines moved up / down.

Scrolling stops as soon as the cursor reaches the end / beginning of the list and display no more changes after pushing the arrow keys.

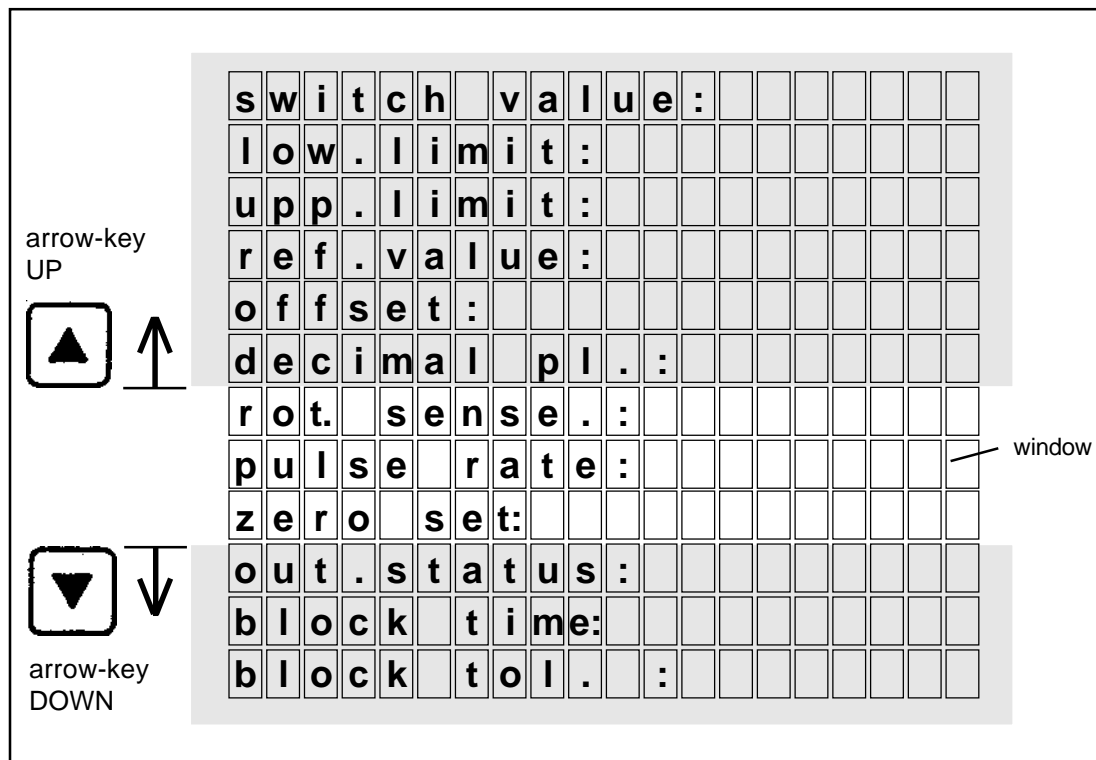

Fig. 5.5: List cutout, with more than 3 lines; window shift by arrow-keys

5.2 Access rights

The access rights to the MX08/2's operating functions can be locked. Especially vital operating functions can be blocked to avoid access by unqualified staff.

Access rights are divided into:

- Access during 'Setup'

(highest access grade)

During installation setting up of the SIKONETZ field-bus system.

Example:

Determination of the axes' counting direction. Normally the counting direction is only determined once, ie. before the first use of the plant. Parameter definition should only be made by qualified personnel. Any wrong parameter modification may lead to faulty measurement.

- Access during 'Starting'

(medium access grade)

To enter production-specific data, which should only be defined by qualified personnel, eg. set-up men, foremen.

Example:

Sets of position values for different products. If these data are wrongly modified, scrap production will result.

- Access 'Operation'

(lowest access grade)

For standard operation of the MX08/2 by the operating staff. Depending on the staff's qualification, this access right also be partially restricted.

MX08/2 access rights are controlled via 4 elements:

- hardware switch S_{int} integrated in the MX08/2
- hardware switch S_{ext} to be provided by the user
- software parameter 'Axis positioning' in the device's parameter menu
- software parameter 'Recipe positioning' in the device's parameter menu

Hardware switch S_{int}

Switch S_{int} is used to release / lock the setup functions. It is situated on the board inside the MX08/2. Use a small screwdriver to activate this switch.

Hardware switch S_{ext}

Switch S_{ext} is used to release/lock setting functions.

For defined unlocking/locking of the setting functions, an external switch must be provided for. Switch S_{ext} is connected to two contacts of the terminal strip on the rear of the MX08/2. If setting functions are not to be restricted, these contacts will not be connected.

Switch S_{ext} and especially switch S_{int} must only be accessible for qualified personnel. In most cases this is already guaranteed by mounting the MX08/2 into a locked console or switch cabinet. If switch S_{ext} must be accessible, use a key switch.

Software parameter 'Axis positioning' and 'Recipe positioning' in the MX08/2's parameter menu

Note:

If you do not use SIKONETZ devices on your machine, which allow axis positioning, these software parameters are without signification. Anyway, in this case menu points 'Axis positioning' and 'Recipe positioning' will no longer be listed in the main menu.

These two software parameters can be programmed in the MX08/2's parameter menu independently from each other.

For parameter programming setup function must be unlocked via switch S_{int} . Then select MX08/2 under menu point 'Devices' parameters'. The MX08/2's parameters and their state will be displayed. Programmed parameters will be stored in the MX08/2's non-volatile memory.

The parameter may be set to one of three states:

- without
- locked
- unlocked

Programming state 'Without':

- axis positioning
- recipe positioning (and thus also automatically recipe programming)

are at no access stage available. The corresponding menu points are no longer included in the main menu lists.

This should only be made :

- If you want to operate your machine without recipe positioning and if all axes are adjusted individually.
- If you use the MX08/2 as interface converter only. In this case the menu points 'Axis positioning' and 'Recipe positioning' are superfluous and may even disrupt operation.

Programming state 'Locked' means, that the functions

- axis positioning
- recipe positioning

are not available for staff whose access grade is restricted to 'Operation'. The functions are still listed in the menu, but displayed as locked, when access is attempted.

The above-mentioned functions and menu point 'Recipe programming' are accessible in access grade 'setup' and 'starting'.

This helps to avoid the machine operator changing parameters programmed by the set-up man.

Programming state 'Unlocked' means, that the functions

- axis positioning (unlocked)
- recipe positioning (unlocked)

are also accessible at the lowest access grade 'Operation'.

Function

- recipe programming

is never accessible in access grade 'Operation' , but only in access grades 'Setup' and 'Starting'.

This programming state may be used to change the programming of the menu point 'Recipe positioning' for a new setting of the machine's axes, especially for applications where the axis position changes quite often due to product changes.

On the other hand access to menu point 'Axis positioning' can be locked to avoid the programming of single axis being modified independently from the other axes.

MX08/2: Access right presetting at the factory

- hardware switch 'S_{int}' = open
- hardware switch 'S_{ext}' = open (not wired)
- software parameter 'Axis positioning' = unlocked
- software parameter 'Recipe positioning' = unlocked

Ex factory all functions are accessible.

Explanation on table 'Access right'

(see overleaf)

- Switch 'S_{int}' open:
All menu points are accessible irrespective of the state of switch 'S_{ext}'. In access grade 'Setup' all functions are entirely accessible.
- Switch 'S_{int}' closed:
The external switch 'S_{ext}' is active and distinguishes between the access grades 'Setup' and 'Operation'.
- Switch 'S_{ext}' open:
In access grade 'Setting' all functions are accessible.
- Switch 'S_{ext}' closed:
Only functions according to access grade 'Operation' are available.
- Software switch 'SW_{AP}' in the MX08/2's device parameter menu. It determines whether function 'Axis positioning':
 - is dropped for all access grades ('without').
 - can be used in access grade 'Starting' only ('locked').
 - can be used in access grades 'Starting' and 'Operation' ('unlocked').
- Software switch 'SW_{SP}' in the MX08/2's device parameter menu. It determines whether function 'Recipe positioning':
 - is dropped for all access grades ('without').
 - can be used in access grade 'Starting' only ('locked').
 - can be used in access grades 'Starting' and 'Operation' ('unlocked').

Table 'Access rights'

Switch position:	S _{int} open	S _{int} closed				
	(S _{ext} irrelevant)	S _{ext} open	S _{ext} closed			
Access grade:	Setup	Setting	Operation			
Function:						
Device parameters	yes	no	no			
Position value display	yes	yes	yes			
Axis positioning ^(*1)	yes	yes	yes	no	yes	no
Recipe positioning ^(*2)	yes	yes	yes	yes	no	no
Recipe programming ^(*2)	yes	yes	no			
	parameter SW _{SP}		unlocked		locked	unlocked
	parameter SW _{AP}		locked.			
			unlocked		locked	

Note:

(*1): irrelevant, if parameter SW_{AP} is programmed to 'without'

(*2): irrelevant, if parameter SW_{SP} is programmed to 'without'

S_{int}: internal hardware switch for access right determination

S_{ext}: external hardware switch for access right determination

SW_{SP}: software parameter to unlocked/lock/delete 'Recipe programming'

SW_{AP}: software parameter to unlocked/lock/delete 'Axis positioning'

5.3 Main menu

After correct start-up, main menu is displayed. The first line displays 'Menu choice'.

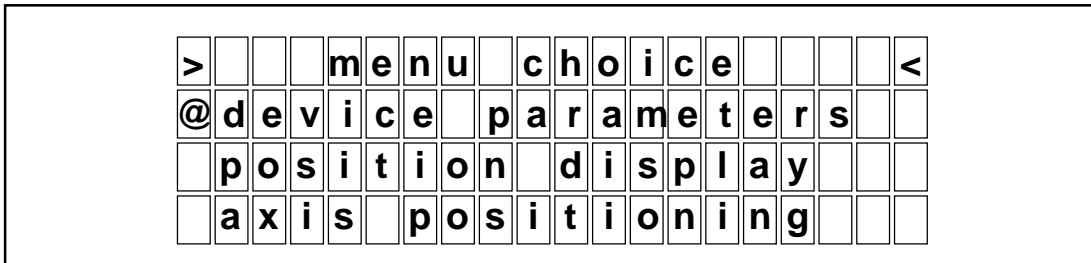

Fig. 5.8: Main menu

Prerequisite: There must be SIKONETZ-devices on the bus and the MX08/2 must have found them during start-up. Otherwise the MX08/2 will display that no SIKONETZ-devices were found and refuse access to main menu.

Depending on access right programming, the MX08/2 lists a certain number of main menu positions.

5 main menu points max. can be selected via the arrow keys:

- device parameters
- position value display
- axis positioning
- recipe positioning
- recipe programming

If access rights are later changed (after programming and setup), the number of main menu points may reduce to 1 min.

Changing to other main menu points

Use the arrow keys 'Up' and 'Down' to scroll main menu list. The cursor indicates the current line.

Press 'Enter' key to confirm your choice. You will then reach the corresponding sub-menu.

Press key F3 to return to main menu. This key has a kind of safety function. If you are several sub-menus away from main menu, key F3 has to be pressed repeatedly for a return to main menu. If you are not sure, press F3 until the display changes no more.

Overview: Main menu points**- Device parameters**

During the machine's setup this menu point is used for programming the connected SIKONETZ-devices and to adjust them to your application. Normally this programming point is only used during machine set-up / starting. Later it may be used to check programming in case of malfunction.

- Position display

Position values (angle and distance) of the connected SIKONETZ-devices are listed. This list gives at any time a overview of the state of your application.

- Axis positioning

Is used for axis positioning. Prerequisite: the connected SIKONETZ-devices must be provided with switching outputs. The devices are listed and the different axes can be selected and finally displaced by stepping mode or target value positioning.

- Recipe positioning

To select out of a list complete sets of SIKONETZ-devices target values and to launch a parallel positioning of all axes. 'Recipe positioning' is a extension of the function 'Axis positioning' and helps save time during machine setting as several axes can be displaced simultaneously. Before, under menu point 'Recipe programming', you have to define values for recipe positioning.

- Recipe programming

To program 'sets' of target value for axes positions ('set' = number of target values for each axis). You can give each 'set' a individual name under which it can be identified and used during recipe positioning.

5.3.1 Menu 'Device parameter'

By parameter programming all SIKONETZ-devices can be adjusted to your application. Parameters are stored in non-volatile semiconductor memories and are not lost in case of supply interruption.

Number and kind of parameter are device-specific. Please use the summary data sheet in appendix A for an overview on the programmable parameters of each device.

The following description concerning parameter programming on SIKONETZ-devices is held as general as possible. Examples, tables and displays are based on one example device, the 'Incremental position display IG08/2'. Program course is more or less identical for all SIKONETZ-devices.

The MX08/2's parameters can also be adjusted according to your application. Chapter 'MX08/2's device parameters' informs about the MX08/2's parameters significance and programming.

Main menu 'Menu choice': choice of menu 'Device parameters'

Previous step:

Main menu must be visible. Remember that you can always return to main menu with key F3 which may have to be pressed several times.

Prerequisite:

Menu point 'Device parameters' is only accessible in access stage 'Setup'. Condition: switch S_{int} must be active (open contact). Otherwise this menu point will not be displayed. Switch S_{int} is preset to 'active' when the MX08/2 leaves our works. In case of questions, please read chapter 'Access rights'.

Description:

The MX08/2's main menu is displayed. The upper line show the title 'Menu choice'. The following lines show among others 'Device parameters' . If you choose this point, you can program the parameters of the SIKONETZ-devices.

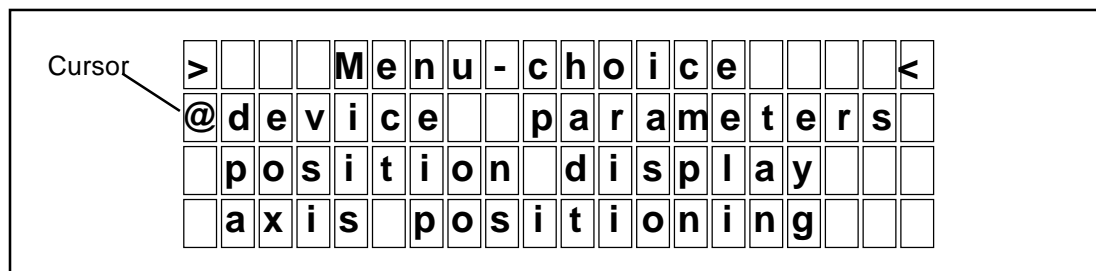

Fig. 5.9: Main menu, selection of function 'Device parameters'

All SIKONETZ-Geräte have a range of parameters (= programmable values, which define the device's functioning). These parameters can be programmed before the first use of your SIKONETZ plant. Ex works all devices are programmed to standard parameters. If these standard values are not suitable for your application, you can list and modify them via the MX08/2. Parameter programming of the different SIKONETZ-devices is carried out from the MX08/2's keyboard and display (just like parameter programming of the MX08/2 itself).

Although parameter programming itself is made via the MX08/2, the values are stored in the non-volatile value memory of the corresponding SIKONETZ device. This means that you can for example program the SIKONETZ-devices from another, separate MX08/2 or from a PC and subsequently integrate these devices.

Next step:

Select with the arrow key 'Device parameters' and confirm with 'Enter'. You now reach menu 'Device parameters', sub-menu 1: device choice'.

Menu 'Device parameters', sub-menu 1 : 'Device choice'

Previous step:

Via cursor you selected in main menu point 'Device parameters' and confirmed it by 'Enter'.

Prerequisite:

- none -

Description:

Menu 'Device parameters', sub-menu 1 = 'device choice' is displayed. The first line shows the headline 'Device parameters'.

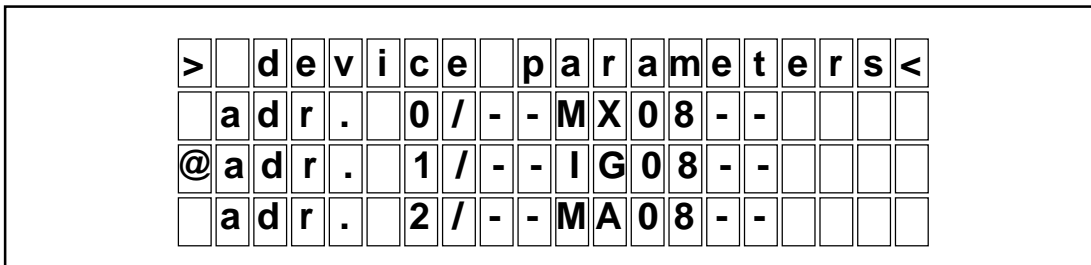

Fig. 5.10: Menu 'Device parameters, sub-menu 1: 'device choice', eg. IG08/2

All devices connected on the SIKONETZ field-bus are listed and displayed. On the left, before the stroke, the device's address is shown; on the right device type, which may either be the manufacturer's product designation or any other name given by you during the previous programming.

The number of listed devices depends on the number of SIKONETZ-devices used and connected on the SIKONETZ field-bus system. If some devices are missing and do not appear in the list, please study chapters 'Address setting' within the SIKONETZ field-bus system, 'Fault finding' as well as the SIKONETZ compendium, which gives basic information on the wiring of the field-bus system. The MX08/2 itself is also listed, as it has several programmable parameters.

Next step:

Use the cursor to select the desired SIKONETZ-device. Confirm your choice by 'Enter'. You will then reach the next sub-menu (= sub-menu 2 'parameter selection').

Menu 'Device parameters, sub-menu 2 : parameter selection'

Previous step:

You selected in menu 'Device parameters, sub-menu 1: 'device choice' the desired SIKO-NETZ-device and confirmed your choice by 'Enter'.

Prerequisite:

- none -

Description:

The display shows menu 'Device parameters, sub-menu 2 : parameter selection'. The headline is still 'Device parameters'. You are now in the list showing the device-specific parameters and the cursor (@) stands before the second parameter.

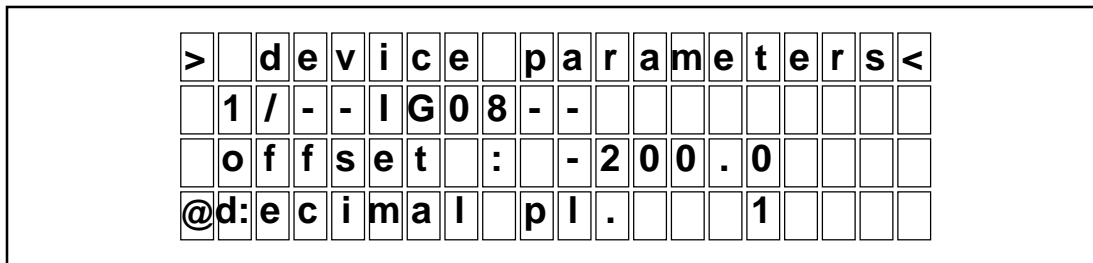

Fig. 5.11: Menu 'Device parameters, sub-menu 2 : parameter selection'.
Example: IG08/2: positions after the comma

Use the arrow keys for parameter selection and confirm with 'Enter' after parameter modification.

Next step:

Use the arrow keys to select the desired parameter. Confirm your choice with 'Enter' and you will reach sub-menu 3 = 'parameter modification'.

Menu 'Device parameters, sub-menu 3 : parameter modification'

Previous step:

You selected a parameter in menu 'Device parameters, sub-menu 2: 'parameter selection' and confirmed your choice by 'enter'.

Prerequisite:

- none -

Description:

The display shows menu 'Device parameters, sub-menu 3, 'parameter modification'. The headline is still 'Device parameters'. In this sub-menu values can be modified. The cursor is on the right at the bottom in the line 'New value'. The previous line shows the presently valid value.

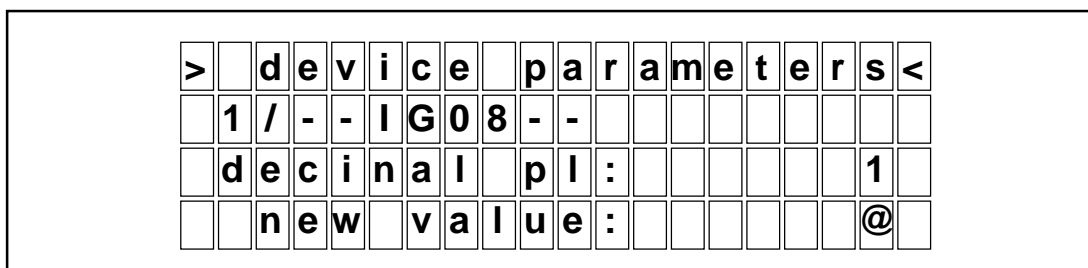

Fig. 5.12: Menu 'Device parameters, sub-menu 3: 'parameter modification', Example IG08/2: new value for 'positions after the comma'

There are two possibilities for parameter modification:

- to select with the arrow keys one parameter from a range of pre-determined values
- to enter a value via the numerical keyboard

The selected or newly entered value must be confirmed by 'Enter'. The new value will be stored in the SIKONETZ-device's non volatile semiconductor memory. At the same time you will return to the previous menu (= 'device parameters', sub-menu 2 'parameter selection').

If, for whatever reason, you do not want to modify the parameter (you changed your mind or got by error into this sub-menu), use key F3 to interrupt and to return to the previous menu without any change of the existing parameter.

Next step:

Use the arrow keys to either select one of the pre-determined values or enter a new value via the numerical keyboard. Confirm your choice with 'Enter' and you will reach the previous menu 'Device parameters, sub-menu 2 'parameter selection'.

5.3.2 Menu 'Position display'

Previous step:

You selected in main menu parameter 'position display' and confirmed your choice by enter.

Prerequisite:

This function is independent from access rights and always available.

Description:

Display of menu 'Position display'. Title in the first line 'Position display'. The following 3 lines show the position values of up to 3 devices belonging to the SIKONETZ field-bus system.

>		p	o	s	i	t	i	o	n		d	i	s	p	l	a	y	<
	2	/	-	-	I	G	0	8	-	-	:				7	.	9	4
	3	/	-	-	M	A	0	8	-	-	:	-	5	0	4	6	.	2
	5	/	-	-	I	G	0	8	-	-	:					0	.	2

Fig. 5.13: Example: 'Position value' display

The list is sorted according to the address numbers. On the left, before the stroke, you find the device's address, then its name (which can either be the manufacturer's product designation or any other name given by you during the previous programming). On the right the position value is displayed, which can - depending on device type and application - stand for an angle, distance or input state (IA08/2).

The MX08/2 is in permanent contact with the SIKONETZ field-bus devices, so that a modification of their position will be immediately displayed.

The number of listed devices depends on the number of SIKONETZ-devices connected to the field-bus system. If some devices do not appear in the list, please study chapter 'Address setting' within the SIKONETZ field-bus system, 'Fault finding' as well as the SIKONETZ compendium, which gives basic information on the wiring of the field-bus system.

The MX08/2 itself is not listed, because it is the master station and does not capture position values.

Next step:

If more than 3 devices are connected, use the arrow keys for scrolling. Press F3 to return to main menu.

5.3.3 Menu 'Axis positioning'

Description:

This function allows axis positioning from the MX08/2. Prerequisite: the used SIKONETZ-devices must be equipped with switching outputs and target value / actual value comparison (see also chapter 'General conditions' overleaf).

If the switching outputs of these devices have been integrated into the axis drive's control circuit, you can via MX08/2

- preset a target value and trigger positioning to this target value,
- change axis position in stepping mode.

The device-specific user information brochures give detailed information on wiring and target values / actual value comparison.

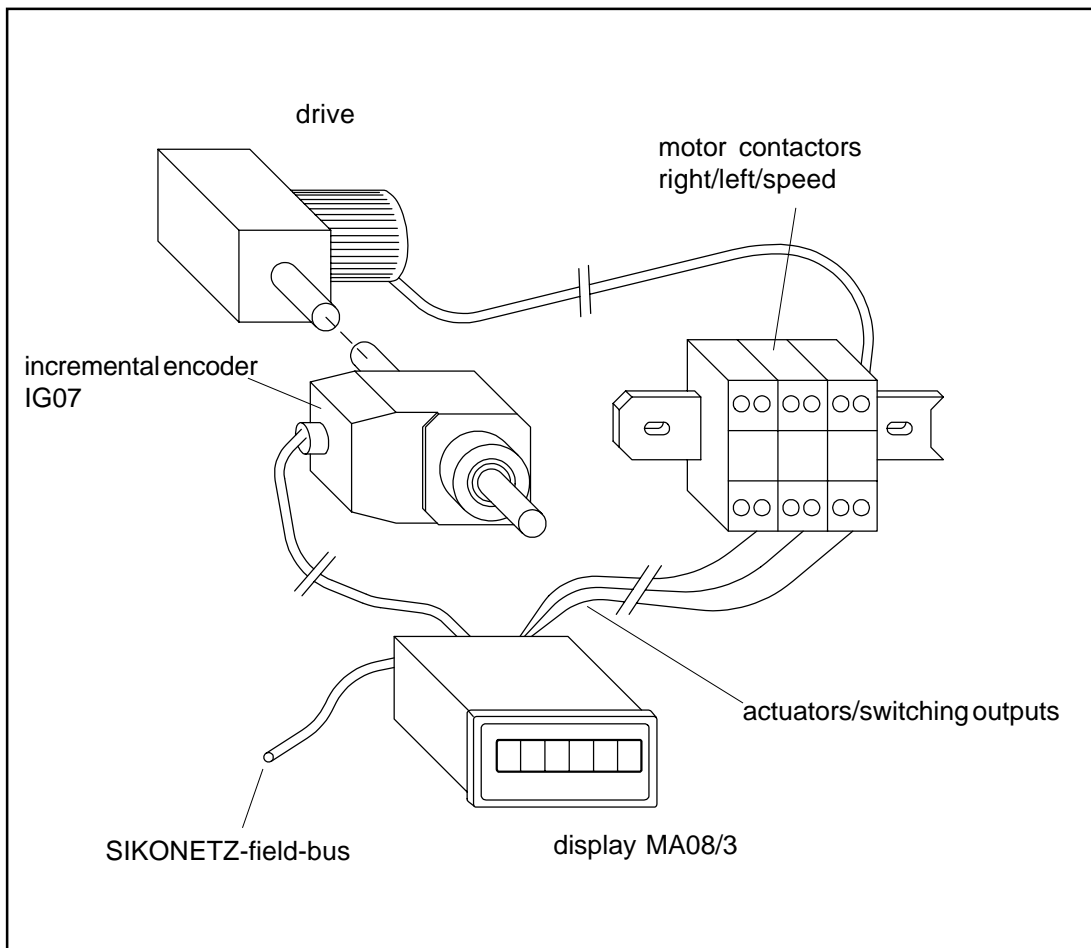

Fig. 5.14: Typical array of SIKONETZ-devices with switching outputs for axis drive control

General conditions:**- Access rights must have been correctly programmed !**

Function 'Axis positioning' depends on access rights (locked or unlocked).

Primarily the state of the MX08/2's parameter 'Axis positioning' determines whether this menu point appears in the display or not.

- If this parameter has been programmed to 'without' , this menu point will not appear in main menu.
- If this parameter has been programmed to 'unlocked' , you always have access to this function, irrespective of the state of the switches 'S_{int}' und 'S_{ext}'. This menu point will always be displayed in main menu.
- If this parameter has been programmed to 'locked' , access depends on the state of switch 'S_{ext}'. If it is open (active), this menu point will be displayed and accessible. If it is closed , menu point 'Axis positioning' will be displayed, but is not accessible.

For detailed information on access rights, please read chapter 'Access rights'.

- There must be SIKONETZ-devices on the bus, which are able to assume positioning tasks !

These SIKONETZ-devices must be equipped with switching outputs (actuators) and target value / actual value comparison. During startup the MX08/2 detects all devices with or without positioning ability.

The following SIKONETZ-Geräte are suitable for positioning and equipped with switching outputs:

- incremental position display IG08/2
- absolute position display AP03
- display MA08/3 for incremental encoders
- display MA30 for absolute encoders

When you choose function 'Axis positioning' , there will be displayed automatically only SIKONETZ-devices with positioning ability. All other devices are ignored.

If there are no SIKONETZ-devices with positioning ability on your field-bus system (eg. only absolute encoders), menu point 'Axis positioning' makes no sense and is not displayed in main menu.

Menu 'Axis positioning, sub-menu 1: 'General'

Previous step:

If

- access to this menu point has been correctly programmed (unlocked)
- and if the bus system includes devices with positioning ability

this function can be activated. Use the cursor to select 'Axis positioning' in main menu and confirm your choice by enter.

Prerequisite:

- none-

Description:

Menu 'Axis positioning' is displayed. The first line shows the headline 'Axis positioning'.

The display always shows the state of only one device.

If the SIKONETZ field-bus systems consists of more than one positioning device, the MX08/2 establishes an internal list sorted according to the address number. Use the arrow keys to scroll this list.

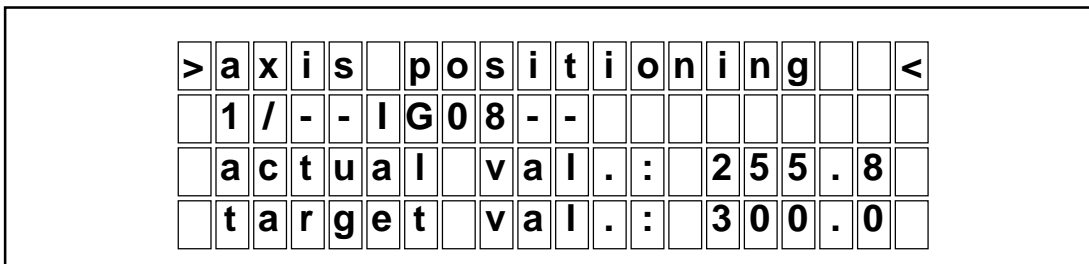

Fig. 5.15: Menu 'Axis positioning, sub-menu 1'

As soon as you reach the beginning / end of the list, the display does not change any more but remains on the first / last device.

Next step:

There are 4 (5) possibilities:

- display of the axes' actual value and target value
- target value modification
- positioning start / stop
- (control display for running positioning process)
- axis positioning in stepping mode

Menu 'Axis positioning, sub-menu 1 : display of axis' target value and actual value'

Previous step:

You selected in main menu parameter 'Axis positioning' and confirmed your choice by enter.

Prerequisite:

- none -

Description:

The last 3 lines monitor the state of a SIKONETZ-device with positioning ability. Please

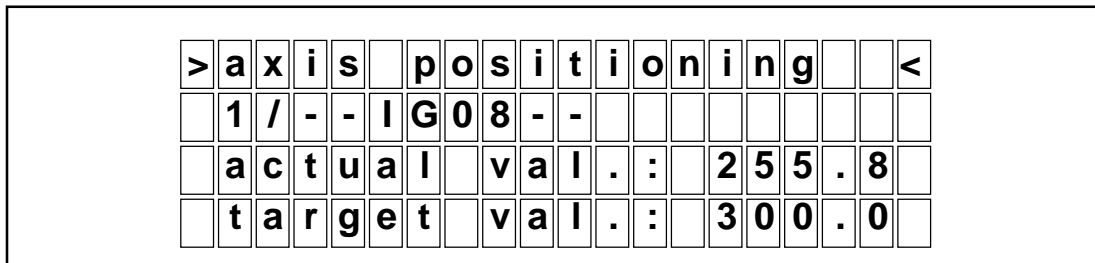

Fig. 5.16: Menu 'Axis positioning, sub-menu 1: target value / actual value display

remember that the display shows the state of one device only!

- The upper line shows on the left device address and after the stroke its name.
- The middle line show the axis' present actual value (either angle or distance)
- The last line shows the present target value
- The cursor is not available, as this is a pure 'Display' menu.

Next step:

You can:

- press key F3 to return to main menu.
- use the arrow keys to choose another device for display.
- change a target value and confirm the modification by 'Enter'. You will then get to menu 'Axis positioning, sub-menu 2 : target value input'.
- position the axis in stepping mode; use arrow keys 'right' and 'left' (menu 'Axis positioning, sub-menu 1: stepping mode').

Menu 'Axis positioning, sub-menu 2 : target value input'**Previous step:**

You were in main menu, parameter 'Axis positioning' and selected a device (via arrow keys). You confirmed your choice by 'enter'.

Prerequisite:

- none-

Description:

The last two lines show the present target value. A new target value can be entered in the last line (behind new value). The cursor is in the last line and ready to enter a new target value via the numerical keyboard. The field 'New value' shows the present target value.

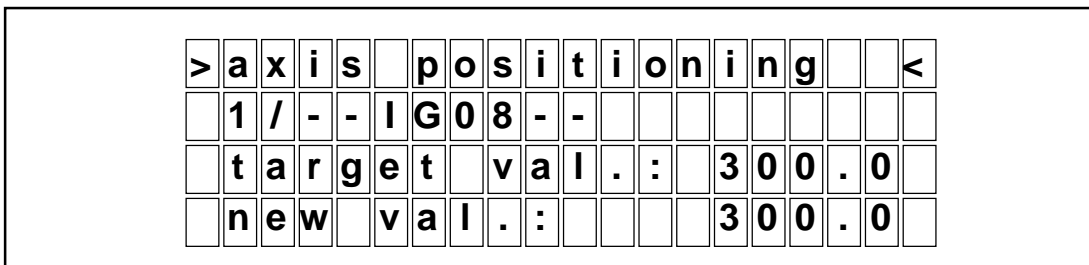

Fig. 5.17: Menu "Axis positioning, sub-menu 1: target value input and/or modification"

Next step:

You can:

- press key F3 to return without target value modification to the previous menu.
- enter a new target value via the MX08/2's numerical keyboard.
- enter a new target value and store it with 'Enter'. In this case you will return automatically to the previous menu.
- interrupt with key F3 and return to the previous menu without target value modification. The old target value will reappear.

Note:

Please remember, that you cannot enter invalid target values. Apart from the usual safeguards in your application (limit switches ...) most SIKONETZ-devices used for positioning, offer the feature 'Limit value control' (see appendix A.5, 'Limit values'). If you use devices with activated 'Limit value control', invalid target values will not be used and an error message will be displayed.

Menu 'Axis positioning , sub-menu 1 : positioning start / stop'**Previous step:**

You controlled and / or entered actual value and target value.

Prerequisite:

- none -

Description:

- Use key F2 to start positioning to the target value.
- Stop positioning at any time by pressing any key. Possibly use key F2 which has ON/OFF-function.
- Press key F2 repeatedly to interrupt and continue positioning.

Next step:

During positioning press any key to start positioning. You will then automatically return to menu 'Axis positioning, sub-menu 1 : display of axis' target value and actual value'

Menu 'Axis positioning, sub-menu 1 : display of a running positioning'

Previous step:

You either started target value positioning with key F2 or changed the axis' position in stepping mode.

Prerequisite:

- none -

Description:

During a running positioning three important values are displayed:

- target value
- actual value
- tendency arrow, which signals direction and speed of positioning (the axis' real moving direction depends on the wiring of the SIKONETZ-device's switching outputs).

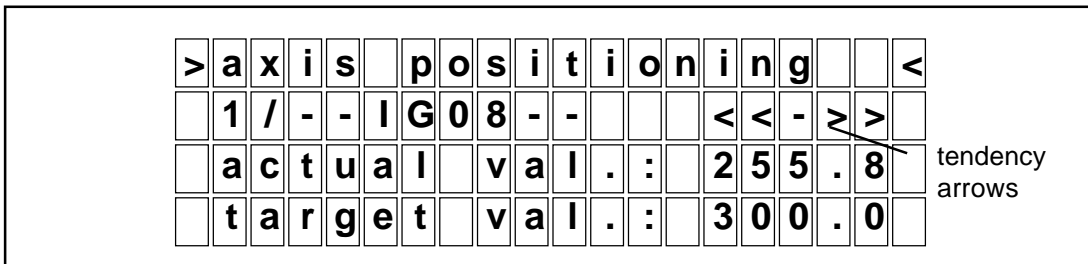

Fig. 5.18: Menu 'Axis positioning, sub-menu 1': tendency arrows

Tendency arrows can adopt 5 states:

-	no positioning, stop	
<-	slow left-hand positioning	(actuator 2)
<<-	quick left-hand positioning	(actuator 2 and 3)
->	slow right-hand positioning	(actuator 1)
-->	quick right-hand positioning	(actuator 1 and 3)

Table 5.2: Menu "Axis positioning, sub-menu 1': tendency arrows

Next step:

Stop current target value positioning by pressing any key, preferably key F2 or stop stepping mode by releasing the stepping keys (arrow right/left). You will then automatically return to menu 'Axis positioning, sub-menu 1 : display of axis' target value and actual value'

Menu 'Axis positioning, sub-menu 1: stepping mode'**Previous step:**

You selected in main menu parameter 'Axis positioning' and confirmed your choice by 'Enter'.

Prerequisite:

- none -

Description:

Use keys 'Arrow left' or 'Arrow right' to activate the axis' drive. As long a one of these keys is pressed, the drive moves in the corresponding direction. The moving direction depends on the wiring of the SIKONETZ-device's switching outputs (actuators). Moving stops as soon as the arrow key is released.

Next step:

After release of the arrow keys you will automatically return to menu 'Axis positioning, sub-menu 1: display of axis' target value and actual value'.

5.3.4 Menu 'Recipe programming'

General description:

Menu 'Recipe programming' allows simultaneous positioning of several axes. Prerequisite: your SIKONETZ-application must include SIKONETZ-devices with switching outputs and target value / actual value comparison (see chapter 'General conditions' overleaf).

With recipe programming, setting time of the axes can be considerably reduced, because the axes will move simultaneously rather than in succession.

Recipe target values, which were defined under 'Recipe programming' function (either a new value was entered or the proposed value was taught-in) are successively and speedily sent to the positioning SIKONETZ-devices, which now start simultaneous positioning.

On the basis of a device-internal target value / actual value comparison, each SIKONETZ-device automatically approaches its target value and, on reaching, sends a confirmation to the MX08/2. Positioning is finished when all axes have been adjusted to their target position.

Positioning can be observed from the MX08/2. Recipe positioning can be interrupted, started or quit at any time.

General conditions:**- Access rights must have been correctly programmed !**

Function 'Recipe positioning' depends on access rights (locked or unlocked).

Primarily the state of the MX08/2's parameters 'Recipe positioning' determines whether this menu point appears in the display or not.

- If this parameter has been programmed to 'without' , this menu point does not appear in main menu.
- If this parameter has been programmed to 'unlocked' , you always have access to this function, irrespective of the state of switches 'S_{int}' und 'S_{ext}'. This menu point is always displayed in main menu.
- If this parameter has been programmed to 'locked' , access depends on the state of switch 'S_{ext}' . If it is open (active), this menu point is displayed and accessible. If it is closed , menu point 'Recipe positioning' will be displayed, but is not accessible.

For detailed information on access rights, please read chapter 'Access rights'.

- There must be SIKONETZ-devices on the bus, which are able to assume positioning tasks !

These SIKONETZ-devices must be equipped with switching outputs (actuators) and target value / actual value comparison. During startup, the MX08/2 detects all devices with or without positioning ability.

The following SIKONETZ-devices are suitable for positioning and equipped with switching outputs:

- incremental position display IG08/2
- absolute position display AP03
- display MA08/3 for incremental encoders
- display MA30 for absolute encoders

When you choose function 'Recipe positioning' , there will automatically only be displayed SIKONETZ-devices with positioning ability. All other devices are ignored.

If there are no SIKONETZ-devices with positioning ability on your field-bus system (eg. only absolute encoders) menu point 'Recipe positioning' makes no sense and is not displayed in main menu.

Menu 'Recipe positioning, sub-menu 1, recipe choice'

Previous step:

You selected in main menu parameter 'Recipe positioning' and confirmed your choice with 'Enter'.

Prerequisite:

Correct access right programming. In case of questions, please read chapter 'Access rights'.

Description:

Menu 'Recipe positioning, sub-menu 1, recipe choice' is displayed. The first line shows the headline 'Recipe positioning'.

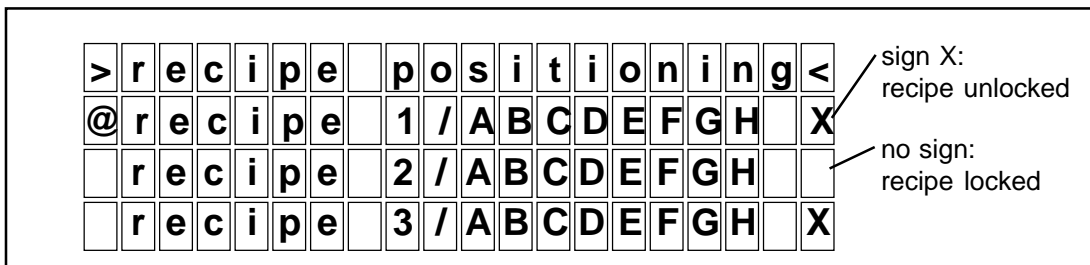

Fig. 5.19: Menu 'Recipe positioning, sub-menu 1, recipe choice'

Three recipes - out of 50 in total (0 to 49) - are displayed in numerical order (recipe number / recipe name). Use the arrow keys to scroll (see also chapter 5.1.4 - Display of long lists via cursor).

Recipes which are not marked with X can be displayed, eg. for target value control, but cannot be used for 'Recipe positioning! Only recipes marked with X are unlocked. Reason for this access restriction is explained in chapter 5.3.5 'Recipe programming'.

Next step:

Use arrow keys 'Up' / 'Down' and the cursor to select one data recipe.

At this stage you can:

- stop and return to main menu with key F3.
- display recipe target values and subsequently start positioning.
In this case press key 'Enter'; you will then get to menu 'Recipe positioning, sub-menu 2, display of recipe target values'

Recipe positioning, sub-menu 2, recipe target value display, start of recipe positioning

Previous step:

You selected via arrow keys a data recipe under main menu parameter 'Recipe positioning, sub-menu 1, recipe choice' and confirmed your choice by 'Enter'.

Prerequisite:

- none -

Description:

This function allows display and control of recipe target values.

The first line still shows the headline 'Recipe positioning'. The second line displays recipe number and name and the third line device's address and name as well as the axis' actual position value. Line four shows the current recipe target value.

.

>	r	e	c	i	p	e		p	o	s	i	t	i	o	n	i	n	g	<
	r	e	c	i	p	e		1	/	A	B	C	D	E	F	G	H		
1		/	-	-	I	G	0	8	-	-	:				7	3	.	5	0
t	a	r	g	e	t		v	a	l	.	:			1	0	0	.	0	0

Fig. 5.20: Menu 'Recipe positioning, sub-menu 2, recipe target value display, start of recipe positioning

If your SIKONETZ field-bus system comprises more than one positioning unit, the MX08/2 issues for each recipe number an address-sorted list with recipe target values. Use arrow keys 'Up / 'Down' to scroll. The positioning units are listed numerically according to their address. As soon as you reach the beginning / end of the list, the display does not change any more.

Remember that you are in the list belonging to the recipe number mentioned in line 2. If you want to display the recipe target values of another data recipe, use key F3 to return to menu 'Recipe positioning, sub-menu 1 recipe choice' and then choose another data recipe.

Next step:

You now have the possibility to start recipe positioning with key F2. Attention! Recipe positioning can only be started for the data recipes marked with X. If you selected a recipe without X, an error message will be displayed.

And you can always use key F3 to return without data modification to menu 'Recipe positioning', sub-menu 1, recipe choice'.

Recipe positioning, sub-menu 3, recipe positioning monitoring'

Previous step:

You pressed key F2 in menu 'Recipe positioning, sub-menu 2, recipe target value display, start of recipe positioning' and thus started recipe positioning.

Prerequisite:

- none -

Description:

The first line shows the blinking headline 'Positioning active'. The second line displays recipe number and name and the third line device's address and name as well as the axis' present position value. Line four show the programmed recipe target value.

The running recipe positioning can be watched. Use arrow keys 'Up / 'Down' to scroll.

p	o	s	i	t	i	o	n	i	n	g		a	c	t	i	v	e		
	r	e	c	i	p	e			1	/	A	B	C	D	E	F	G	H	
1		/	-	-	I	G	0	8	-	-	:				7	3	.	5	0
t	a	r	g	e	t		v	a	l	.	:			1	0	0	.	0	0

Fig. 5.21: Menu 'Recipe positioning, sub-menu 3, positioning monitoring'

As long as axis positioning is running, the headline in line one is flashing. When all axes have reached their target value, display will automatically return to the the previous menu.

Next step:

Press any key (except arrow key 'Up' and 'Down') to stop recipe positioning. Positioning will be instantly interrupted and you will return automatically to the previous menu 'Recipe positioning, sub-menu 2, recipe target value display, start of recipe positioning'. The stopped recipe positioning (eg. to control the actual value ...) can be continued by pressing key F2.

5.3.5 Menu 'Recipe programming'

General description:

This function is used to program recipes of target values. Prerequisite: your SIKONETZ-application must include SIKONETZ-devices with switching outputs and target value / actual value comparison (see chapter 'General conditions' below).

Target value recipes are sets of axis target values. Each set includes one target value for each positioning axis.

When you call, in menu 'Recipe positioning', a target value recipe under its recipe name and then launch positioning, the different target values are successively transmitted to the corresponding SIKONETZ-device and finally positioning is started. All axes are synchronously set to the new target values. Recipe programming helps to save time during axis setting.

Programming:

For recipe programming you have to define a target value for each axis and then to store this data recipe under any name.

There are two possibilities for recipe programming:

- via numerical keyboard (input of a new value)
- by confirming a proposed actual value (eg. by approaching the value in stepping mode or by axis positioning). This is called 'Teach-in', because an existing, 'known' position value is programmed as target value.

Both possibilities may be combined. Example: You can first use 'teach in' to program actual values as target values and then modify the value again via the numerical keyboard.

Number of data recipes:

The MX08/2 allows programming of several independent data recipes. The total number of programmable data recipes depends on:

- MX08/2's memory capacity (RAM)
- number of target values per data recipe (1 min., 31 max.).

The MX08/2 is presently preset at the factory to allow programming of 50 data recipes, each with max. 31 target values.

Recipe name:

First of all data recipes are identified from their recipe number (0 to 49). Moreover data recipes can be individually named, so that the recipe's name already refers to the application. You may for example use as recipe name the name of the product manufactured during this specific production process.

Individual unlocking/locking:

During data recipe programming each data recipe can be individually unlocked or locked for entries. A software flag is used to mark the data recipes accordingly. This marker can be modified at any time.

This allows selection of a number of data recipes and makes only them accessible to the operator.

Data recipes which are temporarily locked can thus not be deleted in error and need not be entered again later.

Summary:

- recipe = sets of axis target values (one value per axis)
- recipe size: minimum 1 target value, maximum 31 target values
- max. numer of data recipes: 50
- recipe number: 0 to 49; recipe name: any (max. 8 signs)
- individual unlocking/locking

Example:

Paletting machine with 5 adjustable axes. Programming has to be made for 3 different products, which are alternatingly handled. You program one data recipe for each product, which could for example read as follows:

Recipe 0,	name 'Kalkohne,	Recipe 1,	name 'Dente,	Recipe 2,	n a m e
Adr. 1 targ.value:30,5		lon',		'Brushfix',	
Adr. 2 targ.value:130		Adr. 1 targ.value: 40,2		Adr. 1 targ.value:16,5	
Adr. 10 targ.value:30,5		Adr. 2 targ.value: 122		Adr. 2 targ.value:89	
Adr. 11 targ.value:130		Adr. 10 targ.value: 40,4		Adr. 10 targ.value:33,0	
Adr. 20 targ.value:5,25		Adr. 11 targ.value: 123		Adr. 11 targ.value:91	
		Adr. 20 targ.value: 5,25		Adr. 20 targ.value:5,75	

To facilitate coordination, the addresses 1 and 2 are used for feeding axes, address 10 and 11 for discharging axes; address 20 was taken for the paletting machine.

Note!

For rules and stipulations on address setting and axis designation, please study chapter 'Adress setting within the SIKONETZ field-bus system'. Please keep in mind that device name and recipe name are different elements.

Device names should refer to the function or place assumed by the SIKONETZ-devices on your machine (Example: 'feeding-top', 'feeding bottom').

Recipe names are 'cues' associating the setting of several axes with one product (example: 'Kar-Z5', 'Kar-BETA').

General conditions:**- Access rights must have been correctly programmed !**

Function 'Recipe programming' depends on access rights (locked or unlocked).

Primarily the state of the MX08/2's parameters 'Recipe positioning' determines whether menu point 'Recipe programming' will be displayed in main menu or not (parameter recipe programming is decisive, both for menu point 'Recipe programming' and 'Recipe positioning').

- If this parameters has been programmed to 'without' , this menu point does not appear in main menu.
- If this parameter has been programmed to 'unlocked' , you always have access to this function, irrespective of the state of switches 'S_{int}' und 'S_{ext}'. This menu point is always displayed in main menu.
- If this parameter has been programmed to 'locked' , access depends on the state of switch 'S_{ext}' . If it is open (active), this menu point is displayed and accessible. If it is closed , menu point 'Recipe positioning' will be displayed, but not accessible.

For detailed information on access rights, please read chapter 'Access rights'.

- There must be SIKONETZ-devices on the bus, which are able to assume positioning tasks !

These SIKONETZ-devices must be equipped with switching outputs (actuators) and target value / actual value comparison. During startup, the MX08/2 detects all devices with or without positioning ability.

The following SIKONETZ-devices are suitable for positioning and equipped with switching outputs:

- incremental position display IG08/2
- absolute position display AP03
- display MA08/3 for incremental encoders
- display MA30 for absolute encoders

When you choose function 'Recipe programming' , there will automatically only be displayed SIKONETZ-devices with positioning ability. All other devices are ignored.

If there are no SIKONETZ-devices with positioning ability on your field-bus system (eg. only absolute encoders), menu point 'Recipe programming' makes no sense and will not be displayed in main menu.

Menu 'Recipe programming, sub-menu 1, choice of programming method'

Previous step:

If

- access has been unlocked by corresponding access right programming
- and if there are SIKONETZ-devices on the bus, which are able to assume positioning tasks

function 'Choice of programming method' can be activated; use the arrow keys to select in main menu parameter 'Recipe programming' and confirm your choice with 'Enter'.

Prerequisite:

This parameter will only be accessible, if the corresponding hardware and software switches were programmed accordingly before. In case of doubts, please read chapter 'Access rights'.

Description:

Menu 'Recipe programming' is displayed. The first line shows the headline 'Recipe programming'.

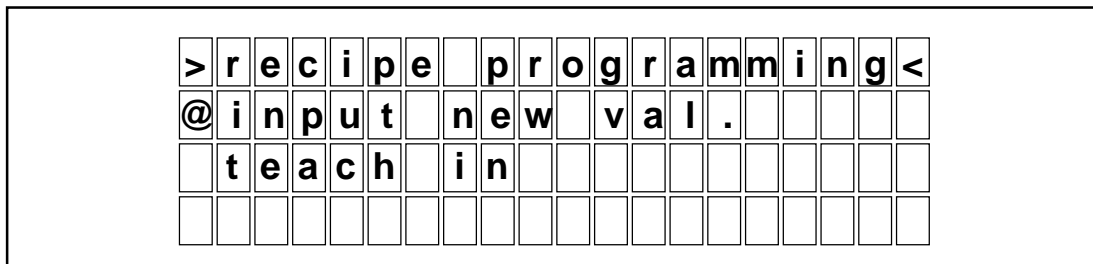

Fig. 5.22: Menu "Recipe programming, sub-menu 1, choice of programming method"

This display offers two methods for recipe target value programming/modification:

- 'Input of a new value'

This menu allows device-specific target value programming via numerical keyboard.

- 'Teach-In'

This menu allows use of either existing actual values or values approached in stepping mode to be programmed as recipe target values.

Next step:

Use the arrow keys to choose either of the two programming possibilities and confirm your choice with 'Enter'.

Menu 'Recipe programming, sub-menu 2, data recipe choice'

Previous step:

Under main menu 'Recipe programming, sub-menu 1, choice of programming method' you selected via arrow keys one possibility and confirmed your choice with 'Enter'.

Prerequisite:

- none -

Description:

Menu 'Recipe programming, sub-menu 2, data recipe choice' is displayed. The first line shows the headline 'Recipe programming'.

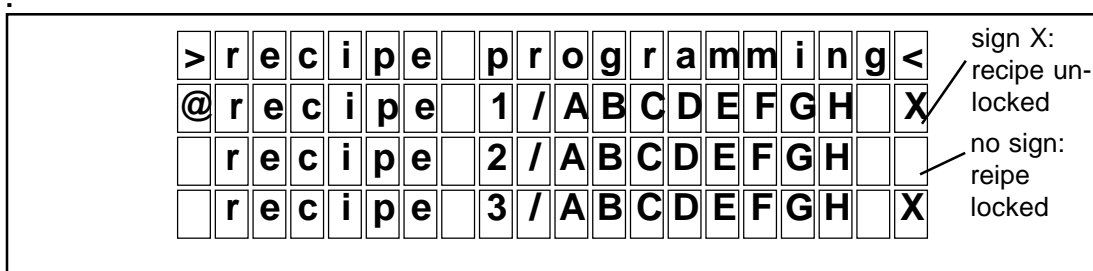

Fig. 5.23: Menu "Recipe programming, sub-menu 2, data recipe choice"

Three data recipes - out of 50 in total - are displayed in numerical order (recipe number / recipe name). Use the arrow keys to scroll (see also chapter 5.1.4 - Display of long lists via cursor).

Next step:

Use the arrow keys 'Up'/'Down' to select one data recipe.

Then you can either:

- Press key F3 to return without modification to main menu.
- Enter/modify recipe name.
Use key 'Arrow right' to get into menu 'Recipe programming, sub-menu 3, entry/ modification of recipe name'.
- Display recipe target values and then enter / take on new recipe target values.
Press 'Enter' key to reach menu 'Recipe programming, sub-menu 3, display of recipe target values'.
- Change the individual software flag (by pushing key 'Delete'), which controls whether a data recipe is locked or unlocked.
You stay in the same menu, but with every use of key 'Delete' you will modify the software flag of the selected data recipe. Recipes marked with X are unlocked, recipes without X are locked and may not be used.

Menu 'Recipe , sub-menu 3, entry/modification of recipe name'**Previous step:**

Under main menu 'Recipe programming, sub-menu 2, choice of a data recipe' you selected via cursors one data recipe and then pressed key 'Arrow right'.

Prerequisite:

- none-

Description:

In this function you can either give the data recipe a name or modify the existing name. A new menu is displayed.

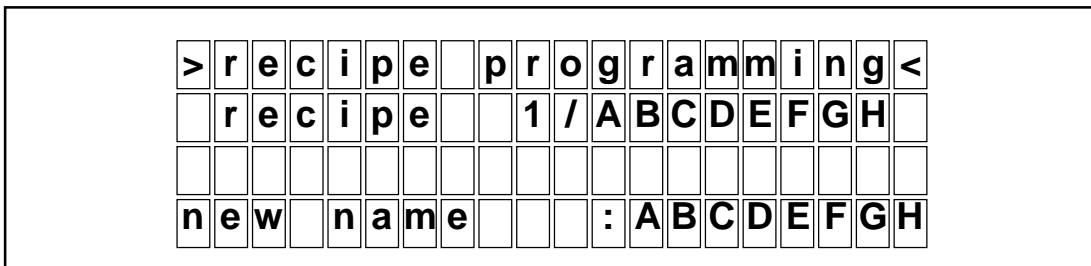

Fig. 5.24: Menu 'Recipe programming, sub-menu 3, entry/modification of recipe name'

Each name can be max. 8 characters long. Ex works the MX08/2 displays the capital letters A to H. If you want to either allocate a new name or modify an existing name, please proceed as follows:

- Use the cursor (arrow key 'Right' / 'Left') to reach the desired digit.
- Use arrow key 'Up'/'Down' to scroll letters and numbers until you reach the desired letter / number.
- Enter the complete name step by step as above.

The arrow keys are repeating keys, ie. when you press them for a longer time, letters and numbers will slowly roll up (down). Release the key to select the desired letter/number. All capital letters and small letters from A to Z, numbers from 0 to 9 and blank are available.

Character sequence:

— ABCDEFGHIJKLMNOPQRSTUVWXYZabcdefghijklmnopqrstuvwxyz 0123456789 —

Next step:

After setting the desired name, confirm and store it by 'Enter'. You will then automatically return to menu 'Recipe programming, sub-menu 2, data recipe choice'.

Menu 'Recipe programming, sub-menu 3, display of recipe target values prior to new value programming'

Previous step:

Under main menu 'Recipe programming, sub-menu 2, choice of a data recipe' you selected via arrow keys one data recipe and confirmed your choice by 'Enter'.

Prerequisite:

Selection of option 'Input of new value' in sub-menu 1.

Description:

This function allows the display and control of the recipe target values of one data recipe.

The first line show the headline 'Recipe programming'. The second line displays recipe number and name and the third line device's address and name as well as one axes' actual position value. Line four show the current recipe target value.

>	r	e	c	i	p	e		p	r	o	g	r	a	m	m	i	n	g	<
	r	e	c	i	p	e		1	/	A	B	C	D	E	F	G	H		
1		/	-	-	I	G	0	8	-	-	:				7	3	.	5	0
t	a	r	g	e	t		v	a	l	.	:			1	0	0	.	0	0

Fig. 5.25: Menu 'Recipe programming, sub-menu 3, entry/modification of a new recipe target value (under programming option 'Input of new value')

If your SIKONETZ field-bus system comprises more than one positioning unit, the MX08/2 issues for each recipe number an address-sorted list with recipe target values. Use arrow keys 'Up' / 'Down' to scroll. For example: if your application includes 8 positioning units, the list will subsequently show 8 devices, their address, name, actual and target value. The positioning units are listed numerically according to their address. As soon as you reach the beginning / end of the list, the display does not change any more.

Remember that you are in the list belonging to the recipe number displayed in line 2. If you want to display the recipe target values of another data recipe, use key F3 to return to menu 'Recipe positioning, sub-menu 2, data recipe choice' and then select another data recipe.

Next step:

Now you have the possibility to enter new target recipe values. Use 'Enter' key to get to menu 'Recipe programming, sub-menu 4, entry of a recipe target value' (programming option 'Input of new value')

And you can always use key F3 to return without data modification to menu 'Recipe positioning', sub-menu 2, data recipe choice'.

Menu 'Recipe programming, sub-menu 4, entry of a recipe target value' (programming option 'Input of new value')

Previous step:

Under main menu 'Recipe programming, sub-menu 3, display of recipe target values' you selected via arrow keys one recipe target value and confirmed your choice with 'Enter'.

Prerequisite:

Only possible, if you use programming option 'Input of new value'!

Description:

This function allows entering of a recipe target value.

The last line is ready for input of a new target value. The cursor stands at the position where a value input is expected. The present target value is displayed in the line above.

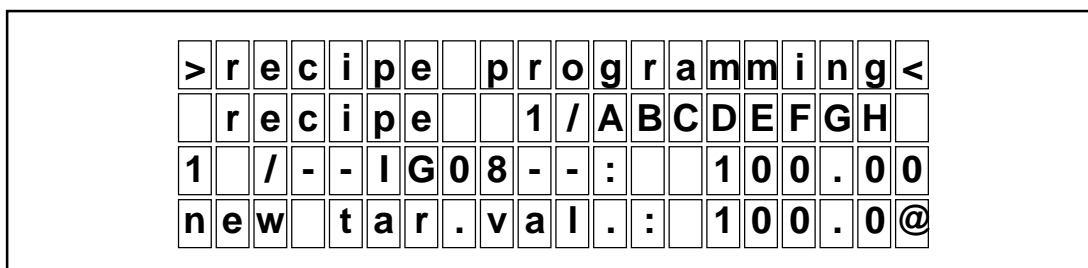

Fig. 5.26: Menu 'Recipe programming, sub-menu 4, entry of a recipe target value'

Provided that option 'Input of new value' was programmed in menu 'Recipe programming, sub-menu 1, choice of programming method' before, a new value can now be entered via the numerical keyboard.

Next step:

Select a value via the numerical keyboard and confirm your choice with 'Enter'.

In any case you can always use key F3 to return without data modification to the previous menu and continue in menu 'Recipe programming', sub-menu 3, display of recipe target value' .

Menu 'Recipe-programming, sub-menu 4, recipe target value display and take-on via teach-In'

Previous step:

Under main menu 'Recipe programming, sub-menu 3, display of recipe target values' you selected via arrow keys one recipe target value and confirmed your choice with 'Enter'.

Prerequisite:

Only possible if you programmed option 'Teach-in' in sub-menu 1.

Description:

This function allows taking on of actual axis position values as recipe target values.

The present recipe target value is displayed in the last line and above the present actual value.

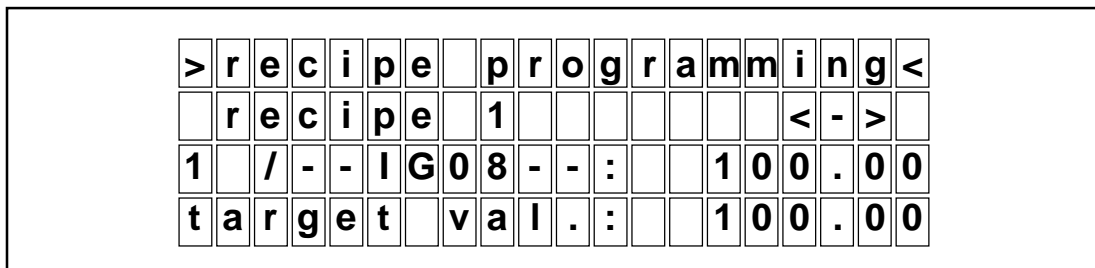

Fig. 5.27: Menu 'Recipe programming, sub-menu 4, take-over of recipe target values'

If you previously programmed 'Teach-In' in menu 'Recipe programming, sub-menu 1, choice of programming method', you have two possibilities:

- The actual position can be changed in stepping mode via the arrow keys UP/DOWN. This corresponds to function 'Axis positioning, stepping mode'. Stepping mode allows setting of the machine to the desired position ('Teaching') and is primarily used for axis fine adjustment.
- The axis' actual value will finally be taken on as new recipe target value.

Next step:

Press 'Enter' key to store the actual value as new target value; automatic returns to previous menu.

In any case you can always use key F3 to return without data modification to the previous menu and continue in menu 'Recipe programming', sub-menu 3, display of recipe target value'.

5.4 MX08/2's device parameters

Previous step:

Return to main menu. Use key F3 to return at any time to main menu; if necessary press it repeatedly.

Prerequisite:

Menu point 'Device parameters' is only accessible during 'Setup'. Prerequisite: switch 'S_{int}' must be active (open contact). Otherwise this menu point will not be displayed. Switch 'S_{int}' is programmed to 'active' when the MX08/2 leaves our works. In case of questions, please read chapter 'Access rights'.

Description:

Main menu is displayed. The first line shows the headline 'Menu choice'. From the following lines you choose 'Device parameters' for SIKONETZ-devices' parameter programming.

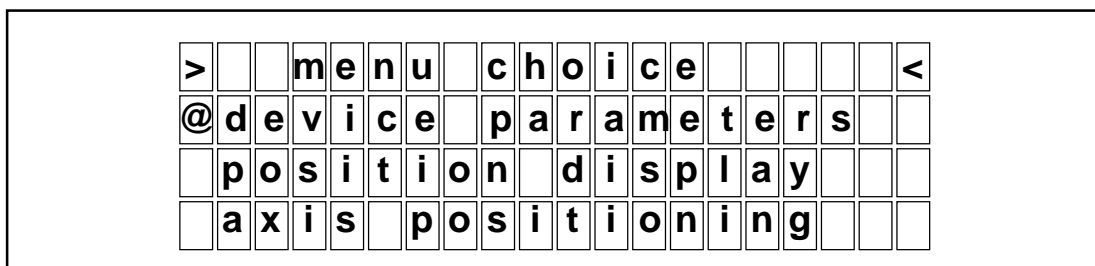

Fig. 5.28: Main menu, selection of function 'Device parameters'

MX08/2 contains several parameters (programmable values determining the MX08/2's functioning), which can be programmed when setting up the SIKONETZ application. Ex works the MX08/2 is preprogrammed to standard values. If these standard values are not suitable for your application, you have to program new parameters under function 'Device parameters'.

The MX08/2's parameters as well as all other SIKONETZ-device's parameters can be programmed via the keyboard and display of the MX08/2. All values are stored in a non-volatile semiconductor memory and can be displayed / modified at any time.

Next step:

Use the arrow keys to select function 'Device parameters'. Confirm your choice with 'Enter' and you will reach the next menu 'Device parameters, sub-menu 1, device choice'.

Menu 'Device parameters, sub-menu 1 : device choice'

Previous step:

Via the arrow keys, you selected in main menu 'Device parameters' and confirmed your choice with 'Enter'.

Prerequisite:

- none -

Description:

Menu 'Device parameters, sub-menu 1: device choice' is displayed. The first line shows the headline 'Device parameters'.

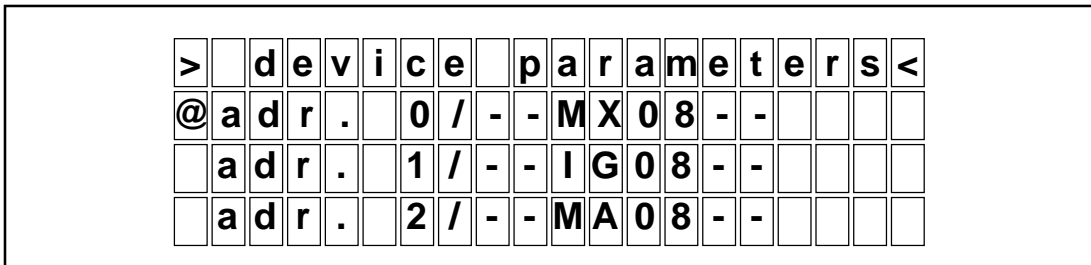

Fig. 5.29: Menu 'Device parameters, sub-menu 1: device choice'

A list of the devices connected on the SIKONETZ field-bus is displayed. On the left, before the stroke, the device-specific address is shown; on the right device name, which may either be the SIKO product designation or any other name you determined during the previous programming.

The first entry in the list shows the MX08/2 itself, which always has the address 0 as it is used as control station.

Next step:

Use the arrow keys to select the MX08/2. Confirm your choice by 'Enter' and you will reach the next menu 'Device parameters, sub-menu 2, parameter selection'.

Menu 'Device parameters, sub-menu 2, parameter selection'

Previous step:

In menu 'Device parameters, sub-menu 1' you selected the MX08/2 and confirmed your choice by 'Enter'.

Prerequisite:

- none -

Description:

A new menu is displayed. The headline is still 'Device parameters'. The MX08/2's parameters are listed and the cursor stands before the first parameter.

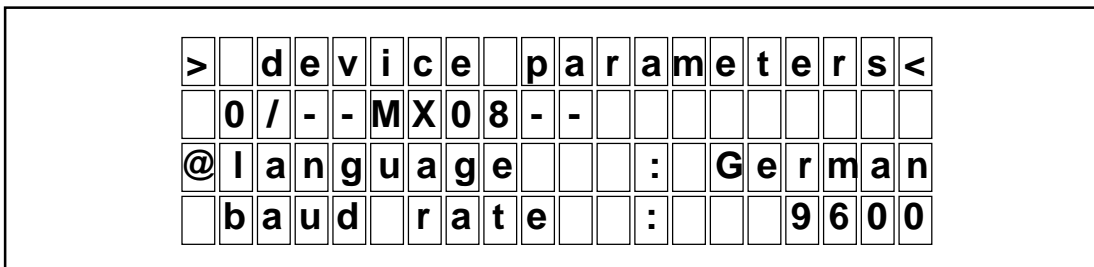

Fig. 5.30: Menu 'Device parameters, sub-menu 2: parameter selection'

There are 6 MX08/2 parameters in all:

Designation	Display	Description
Language	Language	language of display
Baud rate	Baud rate	baud rate of RS232/RS422-interface to control
Display angle	Display angle	determination of an electronic display angle for the LCD-display
Recipe processing	Recipe proc.	determination of access rights for recipe processing
Axis positioning	Axis pos..	determination of access rights for axis positioning
Protocol	Protocol	determination of communication protocol of interface RS232/RS422 to control

Table 5.3: Menu 'Device parameters MX08/2, parameter selection'

Next step:

Use the arrow keys to select the desired parameter. Confirm your choice by 'Enter'. You will then reach menu 'Device parameters, sub-menu 3, parameter modification'.

Menu 'Device parameters, sub-menu 3 : parameter modification'

Previous step:

In menu 'Device parameters, sub-menu 2, parameter selection' you selected one parameter and confirmed your choice by 'Enter'

Prerequisite:

- none -

Description:

A new menu is displayed. The headline is still 'Device parameters'. You are now in a menu where values can be modified. The cursor is in the field 'New value'. This field either displays the last value programmed or the present value.

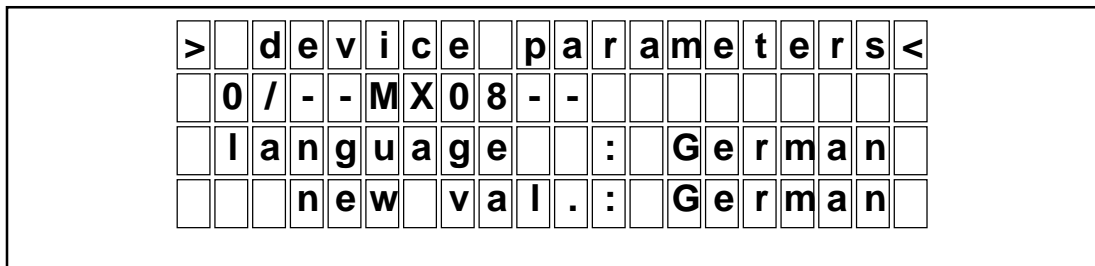

Fig. 5.31: Menu 'Device parameters, sub-menu 3: parameter modification'

Depending on the parameter chosen, you can:

- select via arrow keys from a choice of pre-determined values.
- use the numerical keyboard to enter a new value.

Confirm your choice/input by 'Enter' and the new value will be stored in the MX08/2's non-volatile semiconductor memory. At the same time you will return to the previous menu 'Device parameters, sub-menu 2, parameter selection'.

If you changed your mind and do no longer want to modify / enter a value (or in case you got by error to this menu point), press key F3 to return without modification to the previous menu.

Next step:

Use the arrow keys to either chose one of the proposed values or the numerical keyboard to enter a new value. Confirm your choice by 'Enter' and you will return the previous menu 'Device parameters, sub-menu 2, parameter selection'.

List: MX08/2's parameters**Language**

Options:

- Deutsch (German)
- Francais (French)
- English

Function:

Display in the corresponding language. There is eg. the possibility to make the setup in language 'Deutsch' and to change the language parameter afterwards to 'English'.

Baud rate

Options: [Baud]

- 300
- 600
- 1200
- 2400
- 4800
- 9600
- 19200

Function:

This parameter determines the baud rate of the RS232-interface between MX08/2 and eg. a higher-level control. Please consider that the MX08/2's baud rate and the one of the connected unit must be compatible!

Display angle

Options:

- +3, +2 -3, -4

Function:

This parameters allows adjustment and optimisation of the viewing angle of the LCD-display. Please try several angles to find out the most suitable for your application.

Recipe processing
Axis positioning

Options:

- unlocked
- locked
- without

Function:

This parameter determines the access rights to the MX08/2's functions 'Recipe processing' and 'Axis positioning'. Both parameters are part of the access rights as described in chapter 5.2

Protocol

Options:

- standard (SIKONETZ protocol)
- FB (modified SIKONETZ protocol)

Functions:

This parameter determines the RS232 interface's protocol between MX08/2 and a higher-level control.

5.5 ...an MX08/2 application example

This example demonstrates a typical operation sequence.

The following keys are used:

- arrow key 'Up' / 'Down'
- 'Enter' key
- key F3

The following menus are displayed:

- 'Menu choice', (main menu)
- 'Device parameters, sub-menu 1: device choice' (device choice menu)
- 'Device parameters, sub-menu 2: parameter selection', (parameter selection menu)
- 'Device parameters, sub-menu 3: parameter modification', (value input menu)

You want:

to change the language in which the messages are displayed from German to English to German.

Prerequisite:

- Switch S_{int} must be open.
- MX08/2 must be switched on.
- During startup the MX08/2 has found SIKONETZ-devices on the field-bus.
- You are in main menu, which is displayed as soon as the MX08/2 has been switched on and starting process completed.

Exercise:

Select in main menu point 'Device parameters' by using the arrow keys.

Confirm by 'Enter'.

You now have reached function 'Device parameter programming'. The display shows the headline 'Device parameters' and lists the devices belonging to the SIKONETZ field-bus system.

The headline 'Device parameters' will now always appear in the first line to remind you that you are in the menu, where the parameters of the SIKONETZ-devices can be programmed.

On the left the device's address numbers are listed and on the right either the SIKO product name (eg. MA30, AP03) or another customer-specific designation.

Use the cursor to select from the list the unit with address zero ('Adr.0' = MX08/2). Remember that the total list may be longer than that displayed.

Press 'Enter'.

A new menu (= parameter selection menu) is displayed. The second line of the display shows again device address and SIKO product designation to inform you which device you are going to program.

The two last lines show 2 parameters to which the MX08/2 can be programmed. Use the cursor to move within the list and to select values.

Use the arrow keys to select parameter 'Language' .

Confirm by 'Enter'.

Display changes slightly. The menu, where values can be entered, is displayed and a new language parameter can be entered. The cursor already stands on the field, where the parameter has to be entered.

You have 3 possibilities:

- a) Return without parameter modification to the previous menu by pressing key F3
- b) Confirmation of the old value by 'Enter' and automatic return to previous menu.,
- c) Modification of a proposed values by arrow keys 'Up' / 'Down', confirmation by 'Enter' and then automatic return to previous menu.

Proceed according to c) and select 'English' via arrow keys.

Confirm your choice by 'Enter'.

The display confirms your choice. 'English' will be displayed as parameter language and you will automatically return to parameter selection menu. All text passage are now monitored in English.

Press key F3 twice to return to main menu.

Note !

As an exercise we recommend to try to restore the initial programming of the MX08/2, ie. display in 'German' language.

6. Trouble shooting

Contents

6.1	Fault avoidance	6 - 2
6.2	Trouble shooting procedures	6 - 4

Note!

To avoid trouble and annoyance, we strongly recommend that you proceed very meticulously when setting up the SIKONETZ field-bus system. Especially project planing is of great importance, eg. stipulations on wiring technology, test before first use, lists with device addresses and the parameters which have to be programmed. This will certainly not replace experienced staff during the machine setup, but nevertheless be a solid basis for successful operation of the SIKONETZ field-bus system.

6.1 Fault avoidance

Fault avoidance demands meticulous planning, setup and operation of the system; this will consume additional time.

But this extra expenditure will certainly lower than the costs resulting from a real arising fault, as it is very time-consuming and expensive to detect defects and their reasons and to rectify them - especially when production has to be interrupted.

We therefore strongly recommend use of the follow lists and to respect all information!

Below you will find information on how to avoid faults during the following four stages:

- planning
- setup
- starting
- operation

Planning

Ensure that

- ..., you have complete technical information on the SIKONETZ field-bus system and the devices used on the bus. If you are not sure, please contact SIKO. This manual includes all relevant information on the MX08/2.
- ..., the desired functions can be obtained with your SIKONETZ-devices. Misunderstanding or missing information may lead to disappointment. In case of doubts, please contact SIKO.
- ..., you basically understood the field-bus system's functioning and the hardware/software connection between the units connected on the bus.
- ..., you have a basic command of measuring technology or somebody to ask.
- ..., the different devices are used according to and within the limits of the data stipulated in the device-specific user information brochures.
- ..., you have detailed and comprehensive information on the bus system and its components. If necessary, prepare additional documents with information on the bus system's structure, array, addresses and wiring.
- ..., the programmable parameters have been listed before you start programming; this will help to save time.
- ..., the SIKONETZ-devices (especially master station MX08/2) are accessible during setup and for later service, too.

Setup

Please ensure that

- ..., wiring of the field-bus system is made in exact accordance with the technical stipulations in the SIKO user information brochures.
- ..., wiring has been checked carefully and step by step to ensure that connection lines are neither interrupted nor interchanged and short-circuits will not occur.
- ..., shielding and grounding has been made thoroughly and perfectly.
- ..., all other wiring work, eg. supply, connections to higher level control and to drive units have been established correctly and checked.
- ..., the devices are tightly mounted.
- ..., soldered connections and terminal connections are reliable.

- ..., devices are not exposed to inadmissible, unplanned load .
- ..., devices are not exposed to inadmissible voltages resulting from the plant's set-up or from machine tests.

Starting

Please ensure that

- ..., you proceed step by step and logically. 'Try-and-Error' is seldom a successful method.
- ..., wiring has been checked again before starting the system and that voltage supply is correct.
- ..., initially only the field-bus system and communication lines between the SIKONETZ-devices are commissioned. All other connections, eg. interface to higher-level control and to driving units, must be out of operation (disconnected, fuses removed ...)
- ..., after a first test of the field-bus network, the MX08/2's basic parameters and those of all other SIKONETZ-devices are programmed.
- ..., during starting/test of motoric positioning devices you can resort to safety cut-offs. Check limit switches, overload switches and other safety functions before positioning is started.
- ..., the different positioning axes are put into operation gradually (one after the other) , independently and with correct rotating direction. If necessary, you have to change sign or counting direction.
- ..., first the functioning of the SIKONETZ field-bus system is tested from the MX08/2 and the system is only afterwards connected to the higher-level control.
- ..., all modifications, additions and calibration values are listed and filed.

Operation

Please ensure that

- ..., complete information on the system is available in case of breakdown.

6.2 Trouble shooting procedures

When switched on the MX08/2 does not respond and its LCD-display is dark.

- Is the MX08/2 really supplied with power?
- Has the main supply voltage been switched on (emergency stop, main switch, fuses)?
- Is the main connector on the MX08/2's rear inserted?
- Have cable or plug a defective contact, break or short-circuit?
- Is the voltage correct (alternating voltage, amplitude/frequency?)

Disconnect the MX08/2 completely. Check supply voltage directly on the plug. Connect the MX08/2 again. The LCD-display must monitor the start up sequence; if not, the MX08/2 is defective. If the MX08/2 responds, its other connections to the other SIKONETZ-devices can be gradually established (always switch off MX08/2 and the corresponding device before!). In case of further problems, there might be a fundamental wiring mistake leading to a short-circuit of the supply voltage.

MX08/2 scans the field-bus system, but does not find any connected devices. MX08/2 sends error message "No sub-stations found".

- Is the main connector for the SIKONETZ field-bus on the MX08/2's rear inserted?
- Is the field-bus cable connected to the plug?
- Is the assignment between field-bus signals and cable cores (colors) correct?
- Are all field-bus signals connected?
- Are all field-bus signals connected to the plug's corresponding pin?
- Are the devices used SIKONETZ-compatible devices?
- Have cable or plug a defective contact, break or short-circuit?
- Are the SIKONETZ-devices connected to a supply source?
- Is their voltage supply switched on?
- Did the SIKONETZ-devices get correct addresses (between 1 and 31)?
- Were some addresses allocated twice?

Check all the above-mentioned questions.

It is important that the SIKONETZ-devices are able to respond when the MX08/2 scans the system. This is normally fulfilled if all devices on the field-bus system are connected to voltage supply at the same time. If this is not the case, provision must be made that the MX08/2, which is chronologically the last device on the field-bus, is switched on last.

***MX08/2 scans the field-bus system, but does not find all connected devices.
This error occurs repeatedly when the MX08/2 is switched on.***

- Have the missing devices been connected on the field-bus?
- Are all devices connected to supply voltage?
- Is mains switched on for all devices?
- Are the devices used really SIKONETZ-compatible devices?
- Do the cables/plugs of the field-bus wiring system have any breaks?
- Have some cables of the bus wiring been confused?
- Are all connections established?
- Did the SIKONETZ-devices get correct addresses (between 1 and 31)?
- Were some addresses allocated twice?

Check all the above-mentioned questions.

It is important that the SIKONETZ-devices are able to respond, when the MX08/2 scans the system. This is normally fulfilled if all devices on the field-bus system are connected to voltage supply at the same time. If this is not the case, provision must be made for the MX08/2, which is chronologically the last device on the field-bus, to be switched on last.

***MX08/2 scans the field-bus system, but does not find all connected devices.
This error only occurs sometimes when the MX08/2 is switched on.***

- Is the voltage supply of all devices correct?
- Are all devices switched on at the same time? (or some devices perhaps with a slight delay due to the application state?)
Have cable or plugs defective contacts, breaks or short-circuits?
- Did you thoroughly check the field-bus wiring's cables and plugs for defective contacts?
- Are the field-bus connection lines situated well away from extreme interference sources (cables, machine components)?
- Has the field-bus cable been shielded correctly and connected to ground with low resistance?
- Do, due to wrong cabling, external alternating/direct voltage sources interfere with the field-bus signals?
- Are there short-circuits between the field-bus wiring's signals and other machine components?
- Does the field-bus wiring have a common reference earth?
- Is the common reference earth connected to all devices?

First check all the above-mentioned questions. Please contact SIKO if you cannot eliminate the fault yourselves.

The higher-level control connected to interface I has no access to the field-bus system. The MX08/2 does not respond to its commands.

- Is there an electrical connection at all?
- Have cable or plug a defective contacts, breaks or short-circuits?
- Is the MX08/2 switched on?
- Are the electrical interfaces on both sides compatible?
- Is the data transmission format correct (start, stop, data and parity bits)?
- Is the baud rate correct?
- Have the signals TXD and RXD perhaps been confused?

The higher-level control connected to interface I has no access to the field-bus system. The MX08/2 responds to its commands with an error message.

- Is the data transmission format correct, especially check data such as byte parity, block parity or block CRC?
- Is the MX08/2 in interface converter mode (main menu must be displayed)?

The higher-level control connected to interface I has no access to the field-bus system. The MX08/2 responds to its commands sometimes with an error message but with nothing else.

- Is the baud rate correct?
- Is the data format, especially the telegram length, correct?
- Have the electrical connections been checked for breaks?

The higher-level control connected to interface I has no access to the field-bus system. The MX08/2 responds to its commands, but also issues error messages from time to time.

- Have the electrical connections been checked for breaks?
- Are the electrical lines exposed to high external interferences?
- Is the electrical connection of common earth all right?
- Is common earth exposed to compensating currents resulting from potential differences?
- Does the control generate correct check information (parity or CRC) or are sometimes, eg. depending on the data, wrong check bits issued?

A. Appendix A

Contents

A.1	Overview: Operating structure	A - 2
A.2	Description of the SIKONETZ protocol	A - 9
A.3	Description of the standard protocol	A - 19
A.4	Description of the FB protocol	A - 20
A.5	Glossary: Programmable parameters	A - 21
A.6	Summary data sheets of the SIKONETZ devices	A - 26

A.1 Overview: Operating structure

Main menu 'Menu choice'

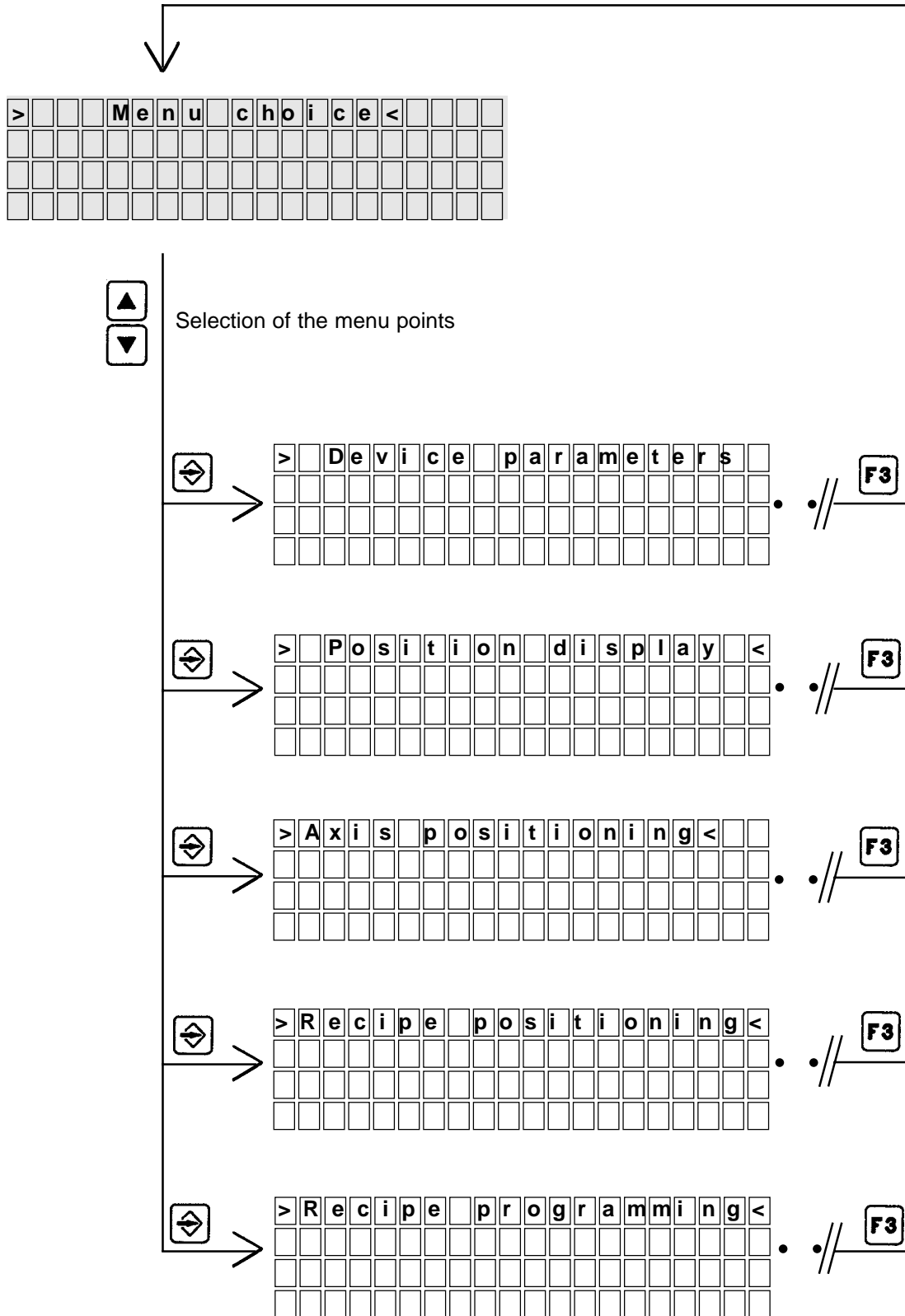

Menu 'Device parameters'

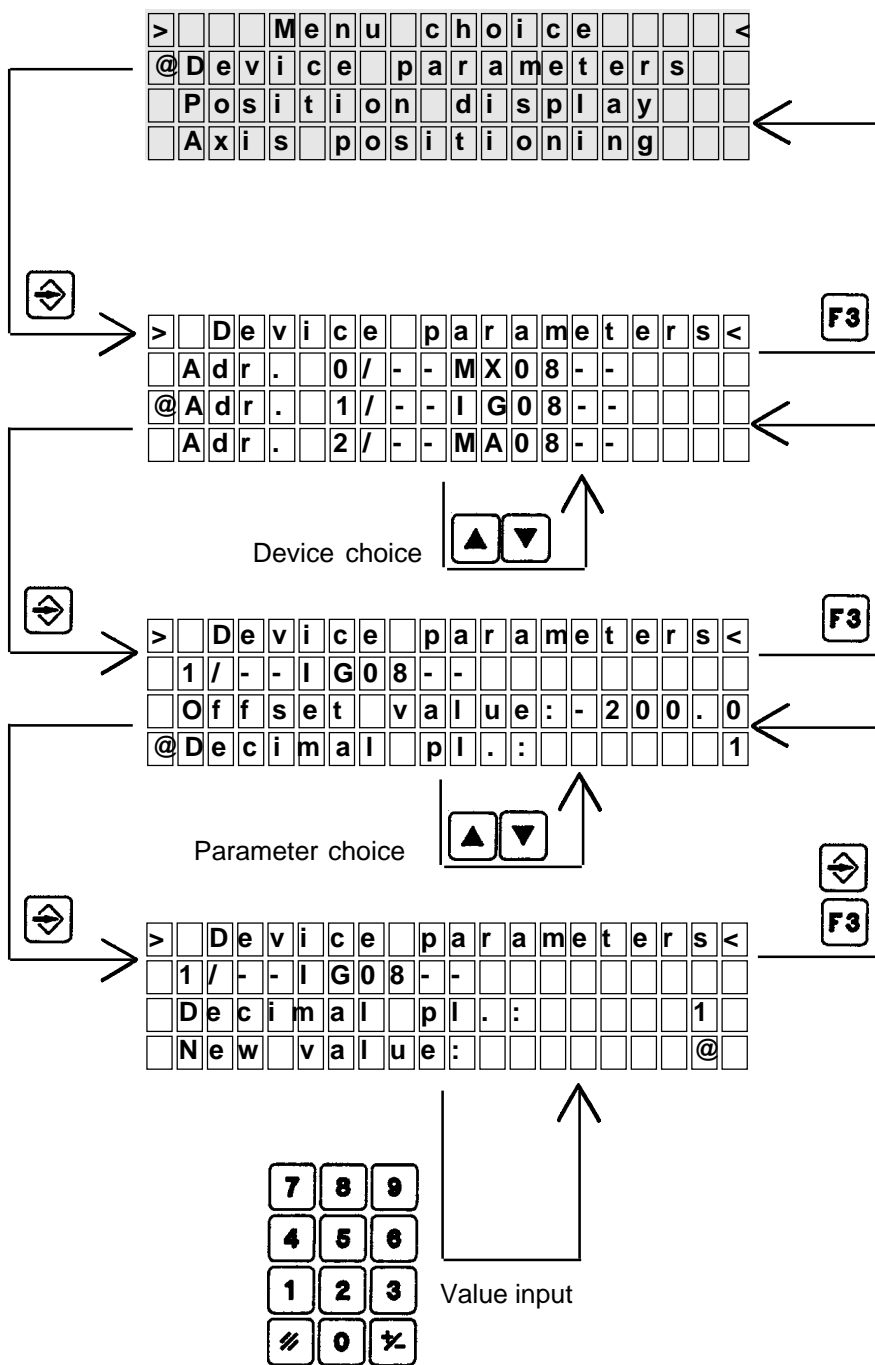

Menu 'Position display'

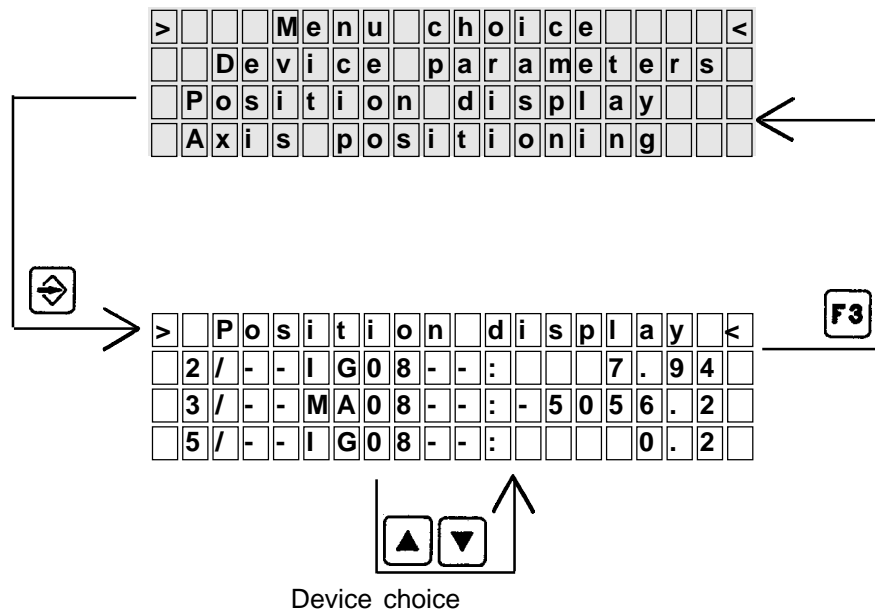

Menu 'Axis positioning'

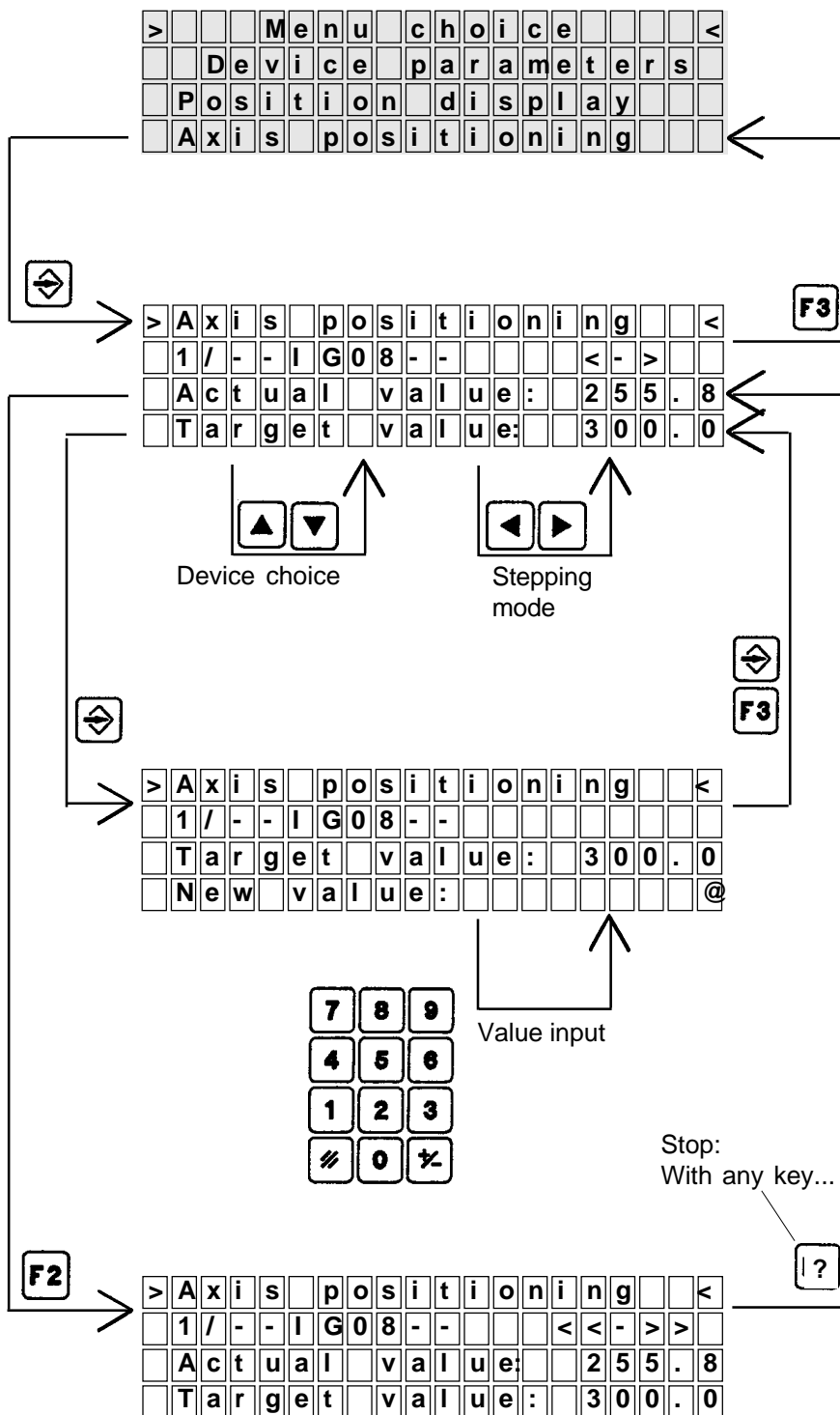

Menu 'recipe positioning'

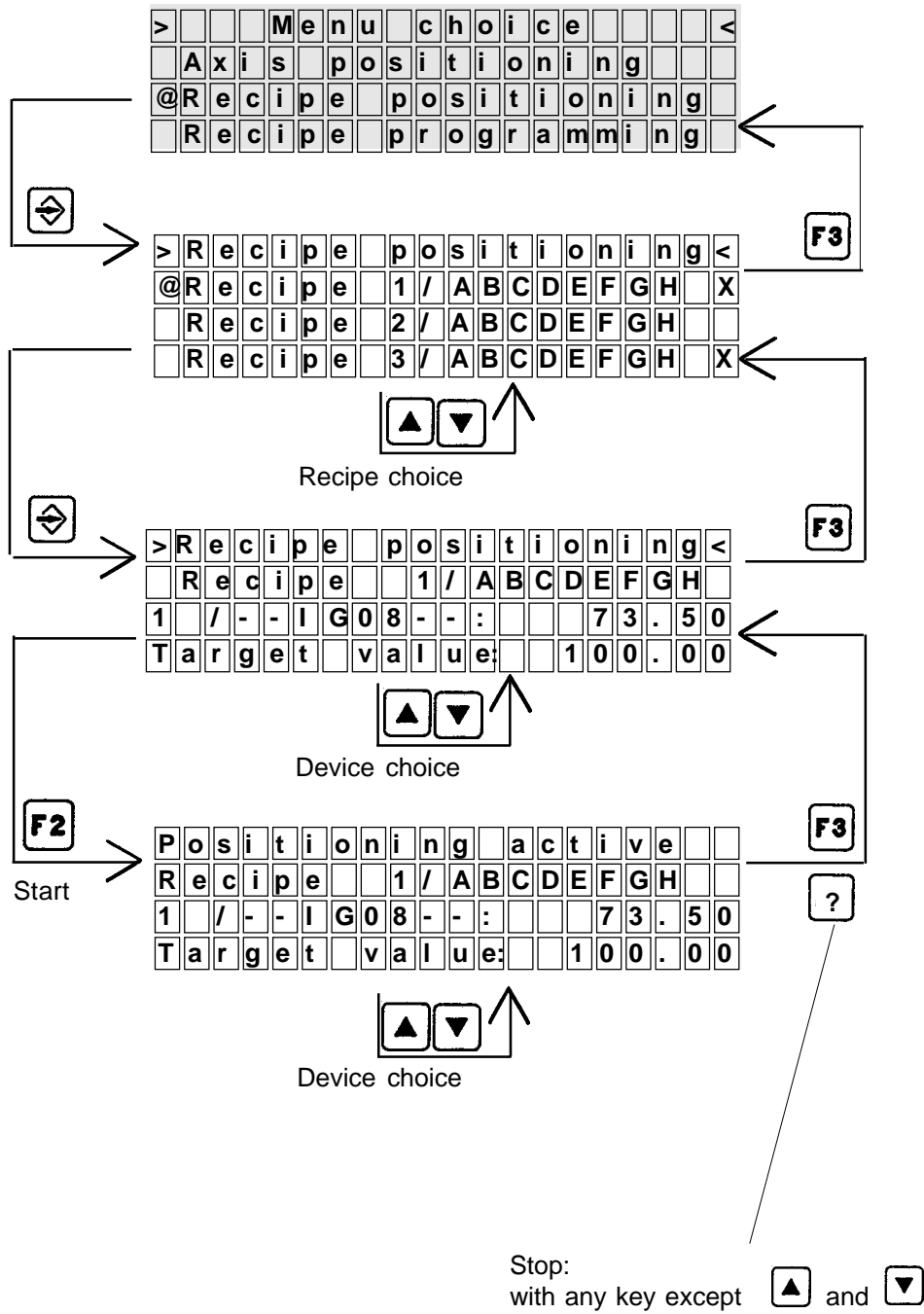

Menu 'Recipe programming by input of a new value'

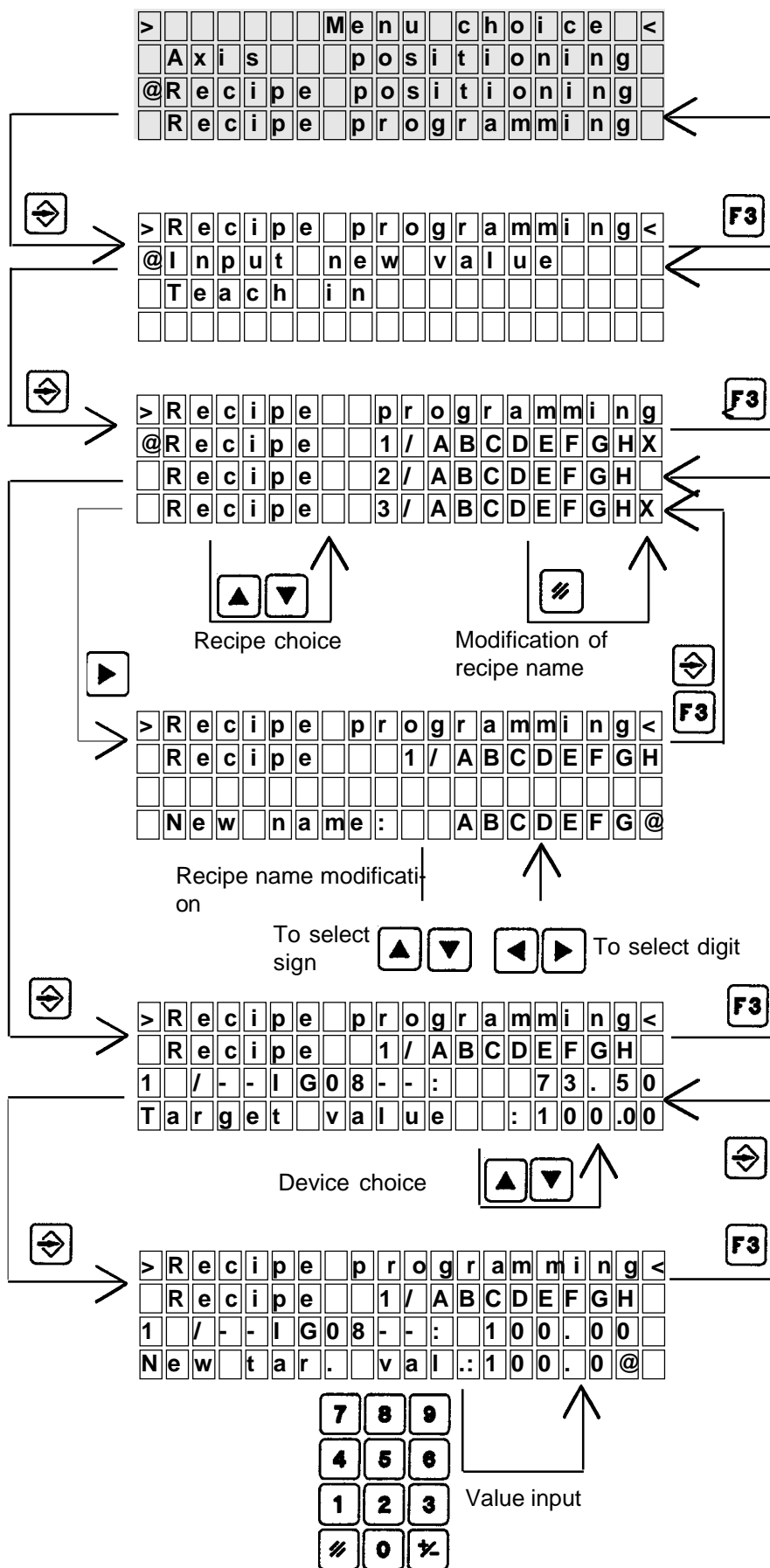

Menu 'Recipe programming via Teach-In'

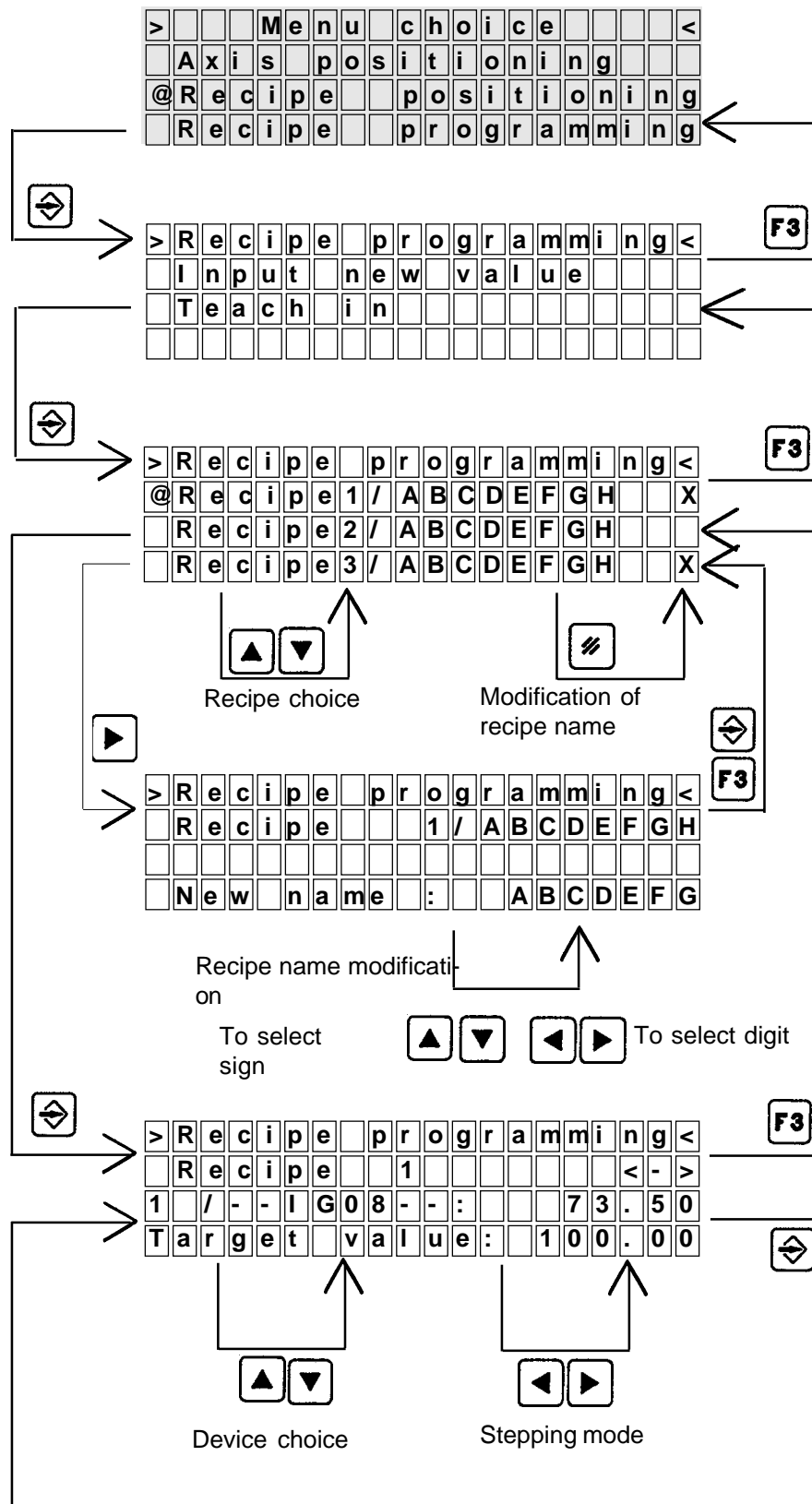

Actual value is stored as target value.

A.2 Description of the SIKONETZ protocol

Contents

A.2.1	General	A-
A.2.2	Telegram format	A-
A.2.3	Telegram description	A-
A.2.4	Telegram components	A-
A.2.5	Data security via CRC-generation	A-
A.2.6	Generation of CRC in software	A-
A.2.7	Example program in C-language	A-
A.2.8	Cycle times	A-
A.2.9	Databus interface RS485	A-
A.2.10	Bus connection and level definition	A-

A 2.1 General

Electrically the SIKONETZ bus uses a RS485 data connection. A maximum of 32 transmitters and 32 receivers can be connected to the bus where in general 1 transmitter and 1 receiver are contained in a device each.

The data transfer on the bus requires a central control station (control unit, which always has address 0) and a maximum of 31 controlled devices (with addresses 1 to 31) which only react when addressed by the control unit with their given address. Operation with various control units is not intended with SIKONETZ bus protocol.

Between messages the bus cables are at rest level. All bus participants are switched into receive mode. This rest level is defined as logical 1 and is achieved via an active bus terminator with predefined resistances between the supply voltage and the screen.

A single communication between one device and another (in future called a telegram) consists of a number of data words. The total definition of their type, order and meaning is called the bus protocol.

On transmission the data words are embedded within a number of data transfer control bits. The asynchronous data transfer used (Start, Stop operation) requires every data word to begin with a start bit and end with a stop bit. This allows synchronisation of the data transfer components in the receiver.

A data word on the RS485 databus consists of 9 bits, which consist of 8 data bits and an extra address identification bit AB.

The address identification bit AB tells the receivers on the bus if the received word is an address or some other sort of data. Simultaneously it indicates the first word in a telegram, allowing synchronisation of binary data as well.

The following abbreviations will be frequently used:

<i>Byte</i>	: 8 bits
<i>U-, M-, O-Byte</i>	: Lowest (Least significant), middle and highest (most significant) byte
<i>Bit Nr. 0</i>	: Least significant bit (LSB) of a byte
<i>Bit Nr. 7</i>	: Most significant bit (MSB) of a byte
<i>Ax</i>	: Address bit no. x
<i>Bx</i>	: Command/message bit no. x
<i>Zx</i>	: Numerical value bit no. x
<i>CRC</i>	: Check word constructed with a Cyclic Redundancy Check (CRC)
<i>Px</i>	: Check word bit no. x
<i>RR</i>	: Broadcast bit
<i>L</i>	: Telegram length bit
<i>AB</i>	: Address identification bit
<i>Start</i>	: Start bit
<i>Stop</i>	: Stop bit
<i>LSB</i>	: Least Significant Bit
<i>MSB</i>	: Most Significant Bit

A.2.2 Telegram format

Two different sorts of telegram format are used:

- Short telegram* a short form with four words,
- Long telegram* a long form with seven words.

Table A.2.1 shows the basic construction of the two telegram formats

	Short telegram	Long telegram
Word 1:	Address	Address
Word 2:	Command/Message	Command/Message
Word 3:	CRC byte 1	Numerical value L byte
Word 4:	CRC byte 2	Numerical value M byte
Word 5:	-	Numerical value O byte
Word 6:	-	CRC byte 1
Word 7:	-	CRC byte 2

Table A.2.1

Numeric values are presented in complementary form.

A.2.3 Telegram description

The diagrams show the form of telegrams in the order they are sent down the bus.

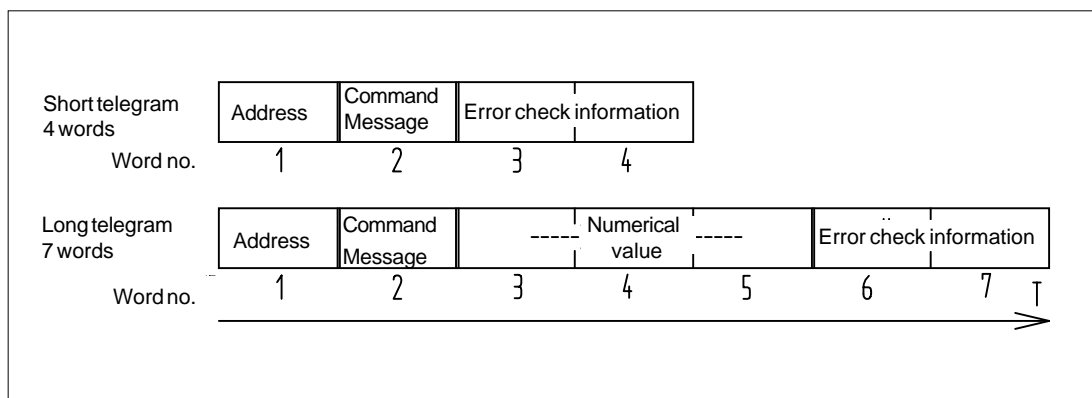

Fig. A.2.1 Telegram format in order time

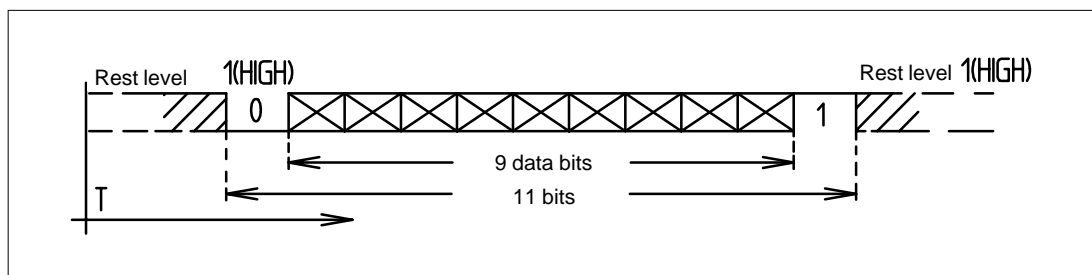

Fig. A.2.2 Time order of single telegram word



A.2.4 Telegram components

Depending on whether a short or long telegram is sent, the telegram contains the parts shown in diagram A.2.3. For short telegrams the numeric value bytes are not used (marked with X).

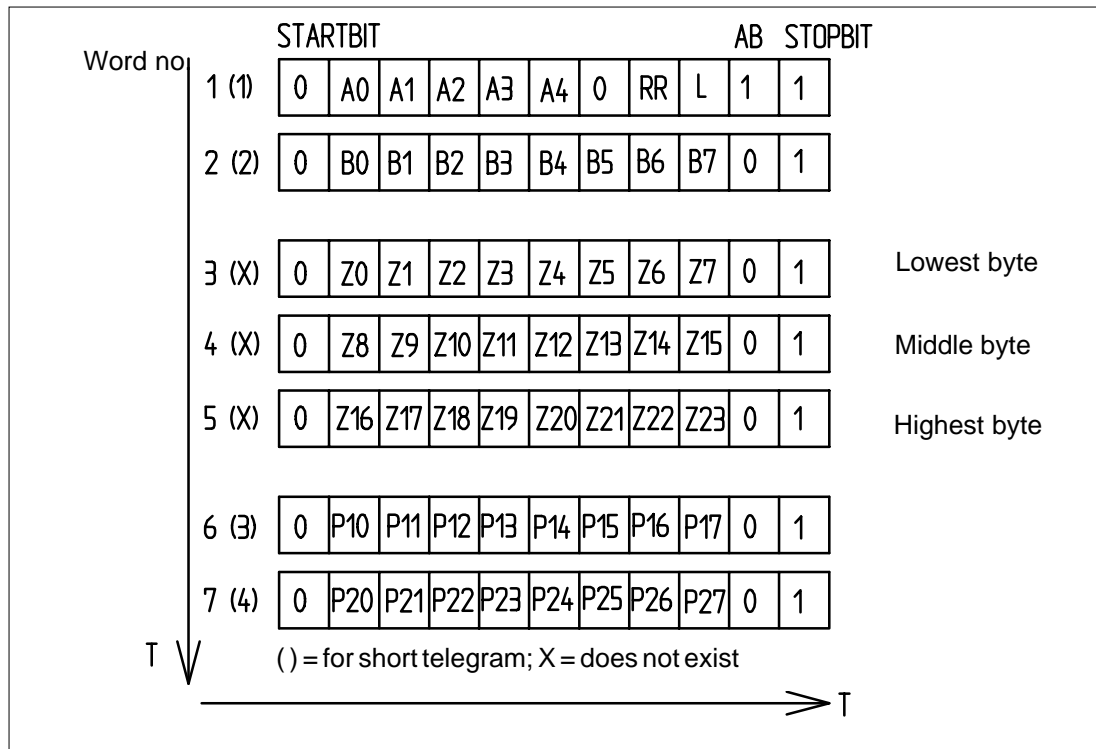

Fig. A.2.3 Components of short and long telegrams

The bits A0, B0, Z0, Z8, Z16, P10, P20 have the lowest value (LSB) in each telegram word.

Address ID bits (AB): always 1 for word no. 1
 always 0 for words no. 2-7

Broadcast bit (RR): 1 for broadcast to all receivers
 0 for direct addressing

Length bit (L): 1 for short telegram
 0 for long telegram

The error check P10 to P27 is generated by the CRC.

Start bit (=0) and stop bit (=1) always have the same value.

Addresses

The device address can be set to any number from 1 to 31. Address 0 always belongs to the MX08 control unit on the bus. Generally this is fixed and cannot be changed. The devices are preset at the factory and must be set to the desired address before they can operate on SIKONETZ with other devices. Each address may only occur once on the bus!

A0...A4, AdrA0...A4, Address bit 0...4 eg.	00000:	Address 0
	00111:	Address 7
	11111:	Address 31

RR, broadcast bit	0:	direct addressing, the message goes to the device with the given address
	1:	Broadcast, the message goes to all devices, the address is ignored
L, telegram length bit	0:	Telegram length = 7 bytes
	1:	Telegram length = 4 bytes
AB, address ID bit	0:	Data bytes
	1:	Address byte (only one in telegram)

Command/message

The commands and messages can be found in the command descriptions of the individual devices (Chapter 5).

B0...B7, Command/Message

AB, address ID bit 0 always the same value

Numeric values

The numeric value can have two meanings depending on the command:

1. As number in range 000000...FFFFFF hexadecimal, in pure binary or complementary form. The range can be restricted according to the device and command.
2. As one, two or three number, eg to indicate functions. In an incremental encoder the pulse edge evaluation can be programmed as 'single', 'double' or 'four fold'. This information is contained in one byte. In such a case several different values can be set in one telegram. The numeric format can vary according to the command and is therefore described for each command.

Z0...Z7, value of lowest byte

Z8...Z15, value of middle byte

Z16...Z23, value of highest byte

AB, address ID bit 0 always the same value

Check word

The check word is calculated by the devices on the bus and attached to the useful data before transmission then checked on reception. The check generates an error message if necessary. The CRC generation and checking are described in chapter 2.1.3 in detail.

P10...P17, lower byte of check word

P18...P27, upper byte of check word

AB, address ID bit 0 always the same value

2.5 Data security via CRC-generation

To increase data security, the SIKONETZ bus protocol embeds a cyclic redundancy check. Its abbreviation is CRC (cyclic redundancy check). Errors that might occur during data transmission can be detected.

Theoretical basis:

The SIKONET bus protocol uses a CRC similar to DIN 66 219 or CCITT V.41. The information bits represent the coefficients of a message polynomial with members from x^{n-1} (n = number of bits in a block or sequence) up to x^0 . This polynomial is divided by the generated polynomial $x^{16} + x^{12} + x^5 + 1$ to modula 2. The check bits are the coefficients of x^{15} to x^0 in the remainder polynomial from the division. The complete block consisting of the information bits followed by the check bits is the coefficients of a polynomial which can be divided by the generated polynomial to modula 2.

Practical realisation:

To generate the 16 bit (2 byte) wide CRC word the sent data is passed through a 16 step shift register with feedback which is set to zero before start. At the end the CRC--word stands in the shift register as a result. This data is then attached to the data to be sent.

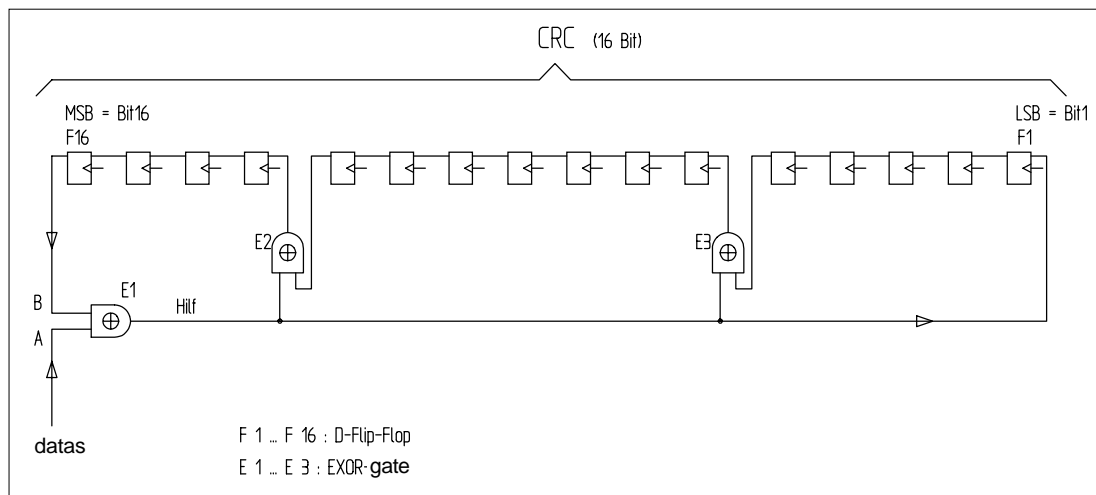

Fig. A.2.4 Circuit diagram of hardware CRC generation

On reception the input bits are passed through an identical shift register. For an error-free transmission all bits in the shift register will be zero. If not, an error routine can be called, which for example requests the data again.

A.2.6 Generation of the CRC in software

In the hardware solution, after zeroing the CRC shift register (see fig. A.2.4), the data, starting with the most significant bit, is input at A. Simultaneously, on every clock cycle, the shift register is shifted 12 bits to the left.

For every clock cycle:

CRC (bit n)	=	CRC (bit n-1)
where n	=	2...5, 7...12, 14...16
CRC (bit 1)	=	"Help"
CRC (bit 6)	=	CRC (bit 5) EXOR "Help"
CRC (bit 13)	=	CRC (bit 12) EXOR "Help"

On translating to software this can be simplified to the following logic:

If "Help"	=	0 (ie. "A" and "B" identical),
then CRC (bit n)	=	CRC (bit n-1)
where n	=	2...16
CRC (bit 0)	=	0

ie. it is simply shifted to the left.

If "Help" = 1 (ie "A" and "B" are non-identical), the above shift operation is also carried out and in addition the new contents of the CRC must be EXORed with the hex constant 1021:

CRC = CRC EXOR (1021 HEX)

A.2.7 Example program in C language

Diagram A.2.5 shows the listing of a function for CRC generation. The function is written in the C language and can be easily translated into other programming languages.

```

/*-----*/
unsigned block_check (int anzahl_zeichen, unsigned char *buffer)
/*-----*/

{
  unsigned int   hilf, crc = 0;
  unsigned char  zeichen, i, j;

  for (i = 0; i < anzahl_zeichen; i++)
  {
    zeichen = buffer [i];
    for (j = 8; j > 0; j--)
    {
      hilf = (crc >> 15) ^ ((zeichen >> (j-1)) & 1);
      crc <<= 1;
      if (hilf == 1)
        crc ^= 0x1021;
    }
  }
  return (crc);
}
/*-----*/

```

Fig. A.2.5 Program listing of CRC generator in C language

With the first "for loop" the program will run as many times as there are numbers in the transmission or reception buffer. The second "for loop" runs eight times so that all eight bits of the character can be processed.

In the line "hilf = .." the MSB of the CRC register and the current bit from the character (starting with the MSB) are filtered out and compared via an EXOR gate. This means that the MSB of the CRC register and the current bit of the data word are shifted to the LSB to allow the EXOR operation.

Then the CRC register is shifted one bit to the left.

If "hilf = 1" the CRC register is EXORed with 1021 hex.

After all these operations have been carried out the function returns the result of the CRC to the calling program.

A.2.8 Cycle times

Two factors determine the cycle times of a telegram in the SIKONETZ data bus system

- the transmission time and
- the processing time.

The transmission time depends on the data transmission rate and the length of the message and answer telegrams. The rate in SIKONET is fixed at 19200 baud. The bit propagation time is therefore 52.08 us. There are two main telegram lengths: 4 byte (short telegram) and 7 byte (long telegram). Every byte consists of 9 data bits and a start and stop bit (see 2.1.2). The time for transmitting a byte is therefore 572.9 us. As the transmission is interrupt controlled the time between two bytes is insignificantly small. The following telegram combinations (message and answer) can occur: 4 / 4 byte, 4 / 7 byte and 7 / 7 byte.

This gives the following *maximum transmission times* for the individual telegram combinations:

Transmission time 4 / 4 byte : 5.583 ms
Transmission time 4 / 7 byte : 6.302 ms
Transmission time 7 / 7 byte : 8.020 ms

The reception of the SIKONET telegrams is interrupt controlled, but the processing of a received telegram is polled once within a device cycle. The cycle time of the SIKONET devices varies with a *maximum of 15 ms*. The processing time is made up of the cycle time, the forming time as well as the control time of the CRC check words. This CRC generation requires approximately 6.5 (4.5) ms for a 7 (4) byte telegram.

This gives the following maximum cycle times:

Cycle time 4 / 4 byte : 28.5 ms
Cycle time 4 / 7 byte : 32.3 ms
Cycle time 7 / 7 byte : 36.0 ms

The basic time frame for short and long telegrams is shown in diagram A.2.6.

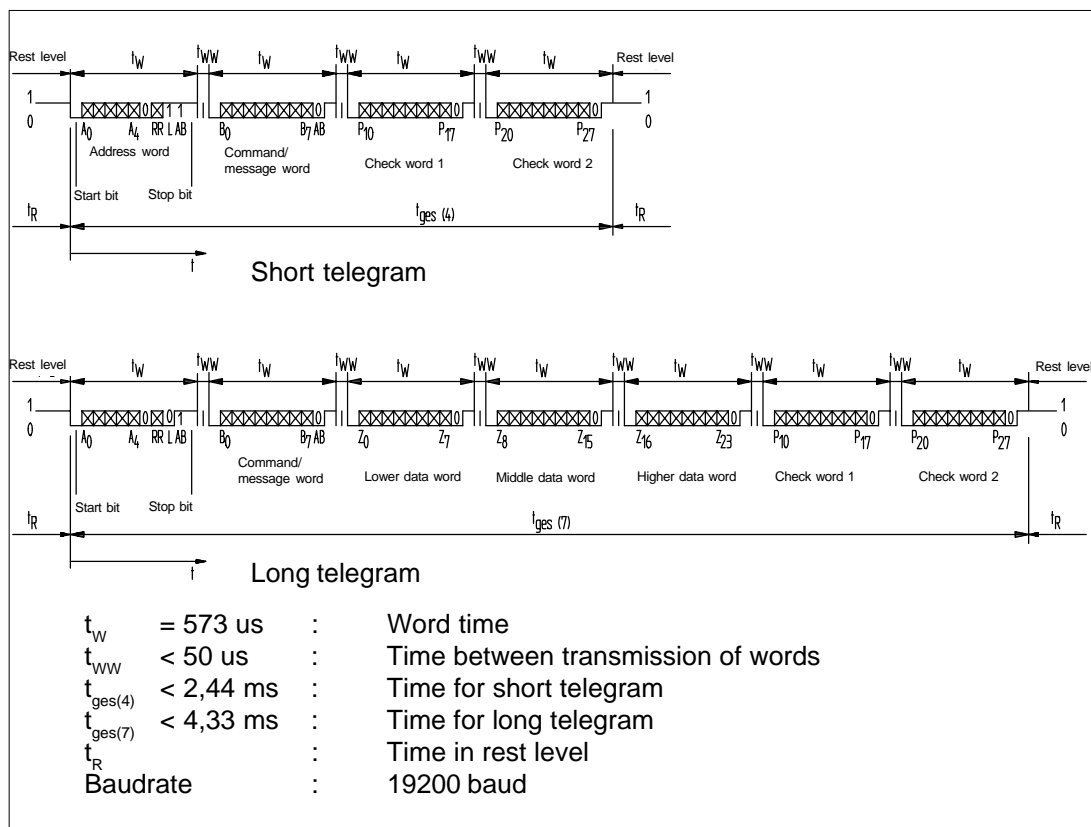

Fig. A.2.6 SIKONETZ time sequence

A.2.9 Data bus interface RS485

- Standard symmetrical, differential interface.
- Bus length up to 1200 m with data rate of 100 kbits/s.
- Bus length up to 20 m with data rate of 10 Mbits/s.
- Transmission medium: screened, twisted, 4-wire cable

A.2.10 Bus connection and level definition

The data signals are transmitted as voltage differences. The difference in voltage must be in the area of 0.3 to 6V. The individual input voltages must not exceed +10V. A bus termination has to be used at the far end of the bus. This consists of a resistance between the signal wires with approximately the characteristic wave impedance of the cable used (120 Ohm for twisted cable). The wiring is illustrated in diagram 2.7 as bus terminator type I. As the bus is bidirectional, the signal level is not defined in the pauses between signals. It is therefore necessary to fix the rest level of the bus using an active bus terminator. Here the signal cable "Data Transmission A" is set to +5V with a resistor and "Data Transmission B" is set with another resistor to signal earth to a fixed rest level. This bus terminator is installed at the other end of the cable (wiring in diagram 2.8, bus terminator type II).

:



The SIKONETZ devices are prepared for bus termination as follows:

Absolute position display AP03	:	solder bridges in connection box
Incremental position display IG08/2	:	solder bridges in connection box
Absolute display MA30	:	bus terminal plug
Incremental display MA08/3	:	bus terminal plug
Multiturn rotary encoder with hollow shaft WK50	:	code switch in connection block
Multiturn rotary encoder with solid shaft WK51	:	code switch in connection block
Singleturn rotary encoder with hollow shaft WK02	:	code switch in connection block
Singleturn rotary encoder with solid shaft WK12	:	code switch in connection block
Intelligent junction box IA08	:	bus terminal plug

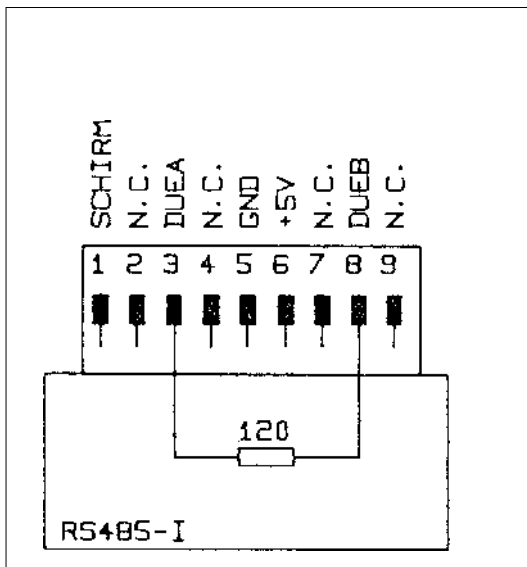

Fig. A.2.7: Bus terminator type I in example of passive level terminator for the bus capable displays MA08/3 and MA30 as well as the intelligent actor

IA08

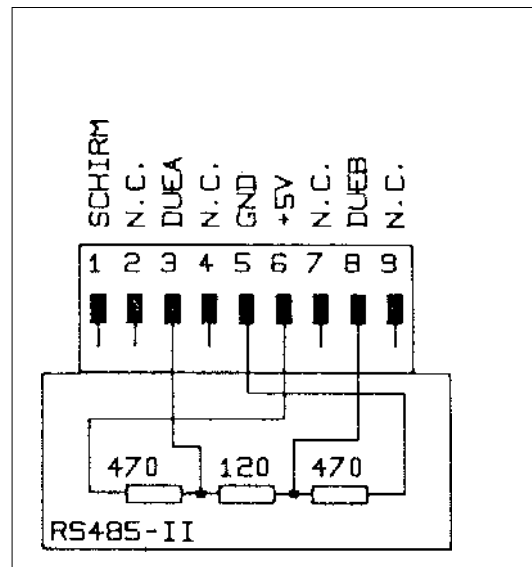

Fig. A.2.8: Bus terminator type II in example of passive level terminator for the bus capable displays MA08/3 and MA30.

A.3 Standard protocol description

If you selected 'Standard' under MX08/2's device parameter 'Protocol', the MX08/2 acts as an interface converter, ie. converts the SIKONETZ protocol between interface II/SIKONETZ-fieldbus into the standard protocol for interface I / master computer or control and vice versa.

Except for a few details, the SIKONETZ protocol remains unchanged. Please study the SIKONETZ protocol description.

Data format: 8 data bits, 1 start bit, 1 stop bit, no parity bit,
the SIKONETZ protocol's address identification bit (AB) is omitted!

Data protection: 2 check bytes for CRC-generation

Telegram length: 4 or 7 bytes

Since the address identification bit is omitted, **synchronisation** for recognition of data telegram start has to be made by **timeout**-technology.

A.4 FB protocol description

If you selected 'FB' under MX08/2's device parameter 'Protocol', the MX08/2 acts as an interface converter, ie. converts the SIKONETZ protocol between interface II / SIKONETZ-fieldbus into the FB-protocol for interface I / master computer or control and vice versa.

Except for a few details the SIKONETZ protocol remains unchanged. Please study the SIKONETZ protocol description.

Data format: 8 data bits, 1 start bit, 1 stop bit, **even parity bit**,
the SIKONETZ protocol's address identification bit (AB) is replaced by the parity bit!

Data protection: **only 1 check byte** for blocking control

Telegram length: **3 or 6 byte**

Since the address identification bit is omitted, **synchronisation** for recognition of data telegram start has to be made by **timeout**-technology.

A.5 Glossary: Programmable parameters

ABI-LEDs

(For incremental display MA08/3 only)

Three light-emitting diodes (LEDs) on the front plate signal the logic level of the signals A, B and I of the connected incremental encoder.

State of actuator

(Only for positioning devices)

The actuator's state is displayed and can be modified by input of values.

Display

(Only for units with display)

The unit's display can be switched on or off. Optionally the SIKONETZ address can be displayed.

Display divider

(Only for units with display)

Value by which the measuring value is divided before it is displayed. This limits the display to a few digits (less than for internal data processing). Standard display divider value = 1. For detailed information please study the device-specific data sheet.

Value displayed per revolution (APU-value)

(Not for intelligent junction box IA08/2)

Value which is added / subtracted from the displayed value after one turn of the incremental encoder. This allows an arithmetic adjustment to any spindle pitch as long as the value is below the encoder's actual resolution. Example: Encoder with 500 increments/ APU = 220 / value displayed after one revolution = 220.

Outputs

(For intelligent junction box IA08/2 only)

Set the outputs to 'On' or 'Off'.

Blocking tolerance

(For positioning devices only, but not for IG08/2)

Distance which during active positioning has to be covered in order to avoid that the drive is blocked.

(See also --> blocking control).

Blocking control

(For positioning devices only, but not for IG08/2)

This parameter switches on/off blocking control. Blocking can for example occur at the limit stops or due to mechanical defects and may lead to a destruction of the drives. If blocking is recognized, the SIKONETZ-device will switch off the drive and thus prevent any damage. Blocking is recognized, if the drive has not passed a defined distance within a certain period.

Blocking time

(For positioning devices only, but not for IG08/2))

Period within which the blocking tolerance (distance) has to be covered in order to prevent the drive from blocking.

(See also --> blocking control).

Device's name

Name which has been given to the device for its identification on the MX08/2's display.

Limit value (control)

(For positioning devices only)

Parameter to switch on/off surveying the adjustment range. The adjustment range is defined by two limit values (upper and lower limit value). If the limit value control is switched on, positioning is only possible within the adjustment range, either by target value input or in stepping mode. Displacements beyond this range are either stopped at the limits or not started at all. The limit value control only works, if upper and lower limit value are not identical.

(See also --> upper limit value, lower limit value)

Pulse multiplication

(For incremental display MA08/3 only)

The pulses coming from the connected incremental encoder can be multiplied by 1, 2 or 4. The electronic counting result per revolution is multiplied accordingly. Example: encoder with 100 increments / pulse multiplication x 2 / counting result after one revolution = 200.

Type of index signal

(For incremental display MA08/3 only)

This parameter must be programmed according to the connected incremental encoder's index signal type. SIKO offers suitable encoders with index signal I or 0. If foreign encoders are used, please contact us to determine correct programming.

Calibration value

Value displayed when the unit is calibrated. Calibration can either be made via hardware (calibrating screw on the AP03) or via software parameter 'Zero-setting' (see below).

Contact type

(For intelligent junction box IA08/2 only)

Parameter to program wiping / permanent contact.

Decimal places

(Not for intelligent junction IA08/2)

Parameter to program the number of positions after the comma. Comma shift is displayed during programming.

Zero-setting

Calibration via software (for absolute units only) or referencing (for incremental units only). The term 'Zero-setting' is not always correct, because the position value of a device is only set to zero (0), if reference value - and in some cases the offset value as well - have been calibrated / set to 0.

Upper limit value

(For positioning devices only)

Value which determines the upper limit of the limit value control range. Must be higher or identical than the lower limiting value. If both values are identical, the limit value control is inactive. (See also --> limit value control)

Offset value

Can be any value, which is subtracted or added during display value calculation. The display value can thus be shifted to any value. For detailed information please study the device-specific brochures.

Reference switch

(For incremental devices only)

The incremental encoder's reference switch and the index signal define the exact reference value position. In practice closing contacts (NC) or opening contacts (NO) are used. Parameter programming must comply with the contact used.

Reference value

(For incremental devices only)

Value displayed when reference switch is closed *and* encoder's index signal appears *and* the encoder's signals are A = High and B = Low .

Switch type

(For intelligent junction IA08/2)

This parameter determines whether the switch is an opening (NO) or closing (NC) contact.

Loop positioning

(For positioning devices only)

This parameter determines, whether the target value is reached by direct or loop positioning. Loop positioning compensates the backlash of the axis' drive.

'Star'-button

(For devices with keyboard only)

This parameter determines the 'Star'-button's function.

Pulse counts

(For incremental display MA08/3 only)

This parameter must be programmed to the number of pulses of the connected encoder. Only this will guarantee a correct calculation of the display value, resulting from APU-value (display after one revolution) and display divisor value.

Keyboard

(For devices with keyboard only)

Parameter to lock / unlock the device's keyboard.

Lower limit value

(For positioning devices only)

Value which determines the lower limit of the limit control range. Value must be lower or identical to the upper limit value. If both values are identical, limit value control is inactive
(See also --> limit value control)

Point of switching

(For positioning devices only)

The value of this parameters determines how far from the target value the drive will switch from creep traverse to fast traverse. This value can only be programmed without sign as it is relative and symmetrical to the target value. The point of switching determines a range around the target value, where the drive will only move in creep traverse.

Wiping time

(For intelligent junction IA08/2 only)

This parameter is of importance only when 'Contact type' has been programmed to 'Wiping contact'. The parameter will then determine the period during which the contact of the switching output is active, if it has been triggered by a corresponding command. After this period the contact will be inactive again.

Counting direction

This parameter determines whether the values displayed increase or decrease when the encoder's shaft is turned (by taking the sign into account!).

A.6 Summary datasheets for SIKONETZ-devices

General

Summary datasheets consist of 2 pages per device.

The first page covers a summary of technical description and the main technical properties of the unit. Page two shows the programmable parameters and the admissible value range for each parameter.

For detailed information on the unit's function, setup and operation, please ask for device-specific 'User information brochures' or 'Manuals'.

Parameter number and sequence is different for each device. The meaning of the parameters is, however, partially identical or similar. Chapter A.5 show an alphabetical list of the parameters and their main functions.

Summary data sheet

'Absolute Position Display AP03'

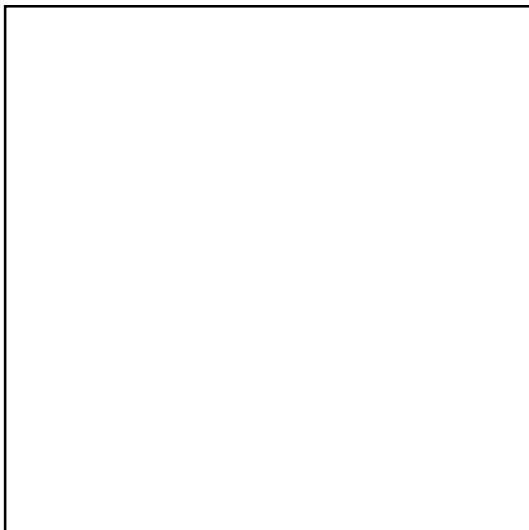

Description

The Absolute Position Display AP03 combines a multi-turn absolute encoder and an intelligent, bus-compatible display in one housing. The unit is mounted directly onto the machine's spindle.

The serial interface allows integration into the SIKONETZ field-bus communication system.

The AP03 assumes 3 functions: data acquisition, display, control.

Three switched outputs (actor outputs) allow positioning (right-hand rotation ON, left-hand rotation On, fast-/creep traverse-switching). Values can be entered and programmed directly on the AP03 via it's keyboard.

Technical data

Dimensions:	(see fig.)
Fixation on the shaft:	via clamping ring
Max. mechanical speed:	3000 rpm
Shaft load, radial:	1.200 N max.
Shaft load, axial:	400 N max.
Housing:	bottom: die-cast metal, upper part: plastic
Shaft:	steel, anodized
Shaft bearing:	double ball bearing
Zero-setting:	either by mechanical rotation of the input shaft or by electrical zero-setting
Weight:	approx. 1.500 g
Coding system:	opto-electronical, GRAYcode
Resolution:	Single-turn component: 1024 steps (10 bit), option: 2048 (11Bit); Multi-turn component: 4096 turns
Supply voltage range:	24 V d.c. +- 20%
Power consumption:	4 VA max.
Working temperature:	0 to +60 °C
Storage temperature:	-20 to +85 °C
Display:	6 x 7-segment, red, 7 mm high, with sign
Connection:	D-sub plug, 15 poles, directly on the indicator; connections for: supply of the unit, received data, supply of the interface, switching outputs. Option: suitable connection box with terminal strips and 3 cable supports
Interface/protocol:	RS485/SIKONETZ
Switching outputs:	3, separated galvanically by opto-coupler, auxiliary external supply is necessary; switching capability max. 30 V d.c., max. 100 mA
Protection:	IP 54

AP03 - parameters

Display	Designation	Value range	Settingvalues
COUNTS/REV	Display after one rev.	0 to 65535
COUNT DIVIDER	Display divisor	1, 10, 100, 1000
COUNT DIR	Counting direction	I, E
DP POSITION	Positions after the comma	0 to 4
CALIBR. VALUE	Calibration value	0 to +-999999
SET CALIBRAT.	Zero-setting	(function, no value)
TURN AROUND POS.	Switching value	0 to 65535
LOOP POSITION.	Loop positioning	Off, I, E
LIMIT EVALUATION	Limit value	On, Off
;AX. WIDTH	Upper limit value	0 to +-999999
MIN. WIDTH	Lower limit value	0 to +-999999
BLOCKING TIME	Blocking time	0 to 999
KEYBOARD	Keyboard	On, Off
'STAR'-BUTTON	Function of 'Star'-key	Stepping, zero, ---
DISPLAY	Display	On, Off, address
ACTUATOR PM	State of actor	0 to 7 (binary)
DEVICE NAME	Device's name	(8 signs)

B. Appendix B

Angle- and Width-Violation-Monitoring System for Dornier TDO Streching Machines for Softwareversion 1.XX of MX08/2 and AP03

schwarz LD 24.12.1994
frö SIKO 5.12.1994
frö SIKO 23.1.1995
frö SIKO 7.3.1995
frö SIKO 8.11.1995

General scope

It is the task of the angle- and width-violation-monitoring system to position (setting up desired stretching ratios) and monitor chain track elements. This is done by controlling the different spindles within a Dornier TDO stretching installation. The following SIKONETZ-components are used, to accomplish this task:

- 1*MX08/2 - central command station and leading part of SIKONETZ II fieldbus
- n*AP03 - absolute position indicator with integrated angle decoders, manual control elements, display and actuator outputs.
n = number of spindles to be monitored and controlled.

The system is capable of controlling 24 spindles at nearly the same time. Positioning can be done in 7 different ways.

1. stepping operation of a single spindle at its own AP03
2. stepping operation of a single spindle at MX08/2.
3. axis-positioning via setting-up desired set-value at its own AP03.
4. axis-positioning via setting-up desired set-value at MX08/2
5. recipe-positioning of all spindles at MX08/2.
6. axis-positioning of single axis via PLC or host computer
7. recipe-positioning of all spindles via PLC or host computer.

In addition the system has to be able to monitor each spindle individually. In case of violating a width- or an angle-limit, movement of the respective spindle has to be stopped and an error is to be given out. This error message is a readable text on the MX08/2 display, together with 2 potentialfree relais outputs at the MX08/2. An optional function is the so called „Line-Shafting“ (LS). It is a mechanical coupling of m adjacent spindles at machine inlet. This constallation has to be taken into consideration when monitoring angle violations. All system components are coupled together via SIKONETZ II fieldbus. The interface is a RS 485 type. Baudrate is 115.2 kBaud. The SIKONETZ II is operated in a master-slave configuration. The MX08/2 always acts as master. For detailed information see SIKONETZ manual or SIKONETZ compendium.

Angle-violation monitoring :

The angles, formed by chain track elements and machine center line, have to be within certain limits. Values for these angles can be set up individually in parameter „angle+“ and „angle-“. Maximum angle is +45° and min. is -45° (in 1° steps). Angle evaluation (angle violation monitoring) is done by comparing the calculated „arcus-tangens“ values with listed limit-values. To do proper calculation, the positions of the adjacent spindles limiting the chain track element, as well as the distance (field length) between respective spindles is necessary. Since positioning and angle-limit monitoring takes place at each spindle, not only the own position value ist required but also the values of the adjacent spindles. Blockage of a certain spindle movement at the AP03 is indicated at the respective AP03 display. Depending on which direction is blocked, the upper or lower segment of the 7th display digit comes on. In case of optional LS, angle-limit monitoring is extended (see description „Line Shafting“). No monitoring takes place when either parameter „field length“ or „angle limit“ is set to „0“.

Width-violation monitoring :

Width-violation monitoring takes place at each AP03 permanently. The two width limit values are stored nonvolatily in the respective AP03. If, during motion, spindle position has reached one of the set limit values, the decimal point of 6th display digit comes on. In addition width-status in the MX08/2 display changes from „0“ to a certain number. This number shows the highest address of AP03, where width-limit-violation occurred.

Order of operation :

After power application MX08/2 scans the SIKONETZ. If all sub-stations (slaves) reply, the MX08/2 switches to converter mode. In this mode of operation, MX08/2 reads position values and status information of each AP03 permanently. So each AP03 receives the position values, necessary for angle calculations, from its adjacent spindles by simply listening to the bus. This mode also allows direct spindle positioning from MX08/2. By choosing the respective menue, axis-, as well as recipe-positioning is possible. If axis- or recipe-positioning has been chosen at MX08/2, individual positioning at AP03 is omitted. In submenu „axispositioning“, a single axis can be positioned with active width- and angle-limit evaluation.

Line Shafting (LS) :

The spindles in the inlet section of the TDO are coupled together in a groupe mechanically. This coupling is called „Line-Shafting“ (LS). Driving the first spindle subsequently moves all elements within the LS-groupe, although each element has an overriding positioning drive on its own. The first spindle has address 01. The number of spindles within LS-groupe (size of groupe) is given by parameter „Line Shafting“. When a LS-groupe is defined, a few special features are activated during recipe-positioning and angle-limit evaluation. A LS-groupe definition is valid when parameter „Line Shafting“ is no longer „0“. In case of recipe-positioning only spindle address „1“ is moved electrically. The drive motors of the remaining spindles within LS-groupe will not be used. The angle-limit evaluation of address“1“ is extended during LS-group positioning. Since spindle 1 drive moves the whole LS-groupe, AP03, address „1“, has to consider the angle formed between the last element of the LS-groupe. Whenever angle-violation occurs, anywhere within LS-groupe, AP03 address „1“ ist stopped. In addition this locking is indicated in MX08/2's display.

Setting addresses :

For proper operation of SIKONETZ II device addresses have to be assigned in a certain order. In general addresses can range from „0“ to „31“. Address „0“ ist definitely reserved for the master controller MX08/2. All axis to be monitored will be given an address, starting with „1“ and continuing gapless to the last one. Address „1“ belongs to the first spindle at TDO's inlet. All following AP03s will be assigned an address in accordance to its appearance within the mechanical order of the whole machine.

Setting-up a new installation :

Set-up of a new installation should be done in a certain manner.

- check all involved wiring
- set device addresses
- switch on device power supply
- switch on interface power supply
- switch on actuator power supply
- set-up AP03 parameters according to parameter sheets

- set-up MX08/2 parameters according to parameter sheets
- set-up plant parameters according to parameter sheets
- calibrate all AP03s
- check ability to position axis, single or in a recipe
- check ability to evaluate angle- and/or width-limit-violation
- if asked for, couple MX08/2 to PLC or any host computer via RS422.

Calibration :

Calibration means, to adapt the display reading of an absolute angle encoder, like the AP03, to its actual mechanical position. Before calibration the count direction (cw or ccw) must be checked, and changed, if necessary. Next the mechanical position of each AP03 has to be found out. Use a steel measuring band to determine the precise distance between the two respective clip tables. This value is to be given into the respective AP03 as calibration value. This programming can be done at the MX08/2 directly, from the PLC, or from a host computer via interface RS422, if connected. Next, the specific calibration is to be carried out for each AP03 by choosing menu line „calibrate“ (zeroing = set starting position) in menu „device parameter“. Pressing „input“ key, the before programmed position value is taken over by the respective AP03. Calibration can also be achieved by mechanically turn the internal AP03 gears via screwdriver.

Initializing the plant from MX08/2 :

Since it is rather time consuming and therefore sensitive for mistakes, programming a bigger installation with up to 24 spindles locally from each AP03, a new menu „plant parameters“, was initiated, to enable the operator to do programming of all device parameters within the whole installation from MX08/2 and then send it out to the AP03s via SIKONETZ fieldbus. This menu line is located in the top menu (converter-, controller-mode). After selection the following 5 submenus appear:

- No. of Spindles - amount of axis/AP03 to be handled
- Line Shafting - amount of axis/AP03 in LS-group
- Zone length - distances between adjacent spindles
- Angle limit - upper and lower angle-limits in respect to the following chain track elements.
- Initialization - hand over the parameters to the respective device.

This kind of parameter setting lets the operator handle less parameters. This is pointed out by the following example:

Zone length „d1“ of AP03, address „7“ is identical to „d2“ of AP03, address „6“ and therefore has to be programmed only once.

Display and operating elements of AP03 :

In addition to the actual position values the AP03 display indicates status informations. A width violation is indicated by the decimal point of the 6th display digit. When axis positioning is running the decimal point, set with parameter setting „dp position“, flashes. When angle-limit violation occurs, the top or bottom element of 7th display digit comes on, whichever is true.

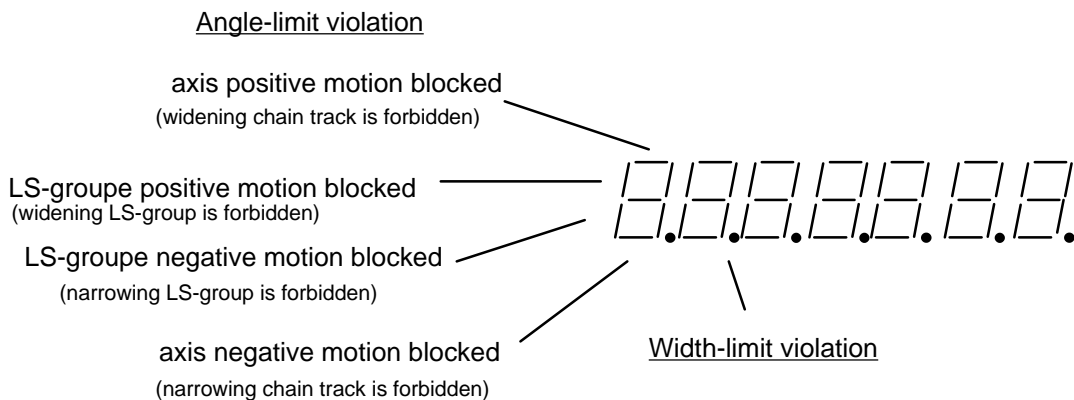

The three key buttons on each AP03 may be used to position the respective spindle (axis) manually. In stepping mode, one of the arc-buttons together with the star-button have to be pressed to move the respective spindle. To give in a new set-value, simply push both arc-buttons together. Next the set value may be changed by first choosing the decade to be changed with the right arc-button and than change numbers by using the left arc-button. The positioning is started by pushing the star-button.

Coupling the whole plant to PLC/PC computer via interface :

Merely all actions of the MX08/2 may be initiated by an external device using an interface. To get proper performances some definitions have to be agreed and kept. Interfaces to PLC/PC can be a RS232 or a RS422 type. Both use no hardware handshake. In device parameters for MX08/2 one of the two protocols can be chosen: „standard“ or „FB“. Standard uses 8 databits and no parity. Two checkbytes are added to each telegram. A CRC routine generates these two checkbytes. For the „FB“ protocol however the telegram consists of 8 databits and 1 even-parity bit. For this protocol the check information is a block-check-byte. It is generated by an EXOR combination of all bytes of a transmitted telegram. Baudrate can be varied by a device parameter between 300 and 19200 Baud. Since we have a binary transmissions, the telegram is synchronized by time synchronisation. See MX08/2-manual or SIKONETZ-compendium for more information about protocols and command structure.

Axis positioning via interface :

A command structure for positioning an axis might look as follows:

Each line stands for a telegram to be sent to an AP03. Addresses and commands for the specific AP03 have to be added to the lines to reach a certain AP03.

1. SWU send set value
2. SSL clear status, all error messages and statistic infos will be deleted.
3. START start positioning
4. SSA read out system status
5. repeat line 4 until actual value meets set value or until error occurs.

Recipe positioning via interface :

A command structure for positioning a recipe might look as follows:

Each line stands for a telegram to be sent to the MX08/2. Address and commands for MX08/2 have to be added to the lines.

1. PREIN switch MX08/2 to programming mode
2. ASNU hand over number of actual recipe (e.g. „5“ for recipe 5)
3. SSA read out recipe status
4. MODA read out MX08/2's actual mode of operation.
5. Repeat from line 3 until actual value meets recipe value or until error occurs. For safety reasons, the recipe positioning is canceled when an error occurred. If recipe positioning was chosen from MX08/2 keyboard during external positioning, an error message is displayed. When an error message occurs during recipe positioning via interface, MX08/2 changes mode of operation to controller mode.

Definition of angle evaluation :

The angle to be evaluated is per definition the angle of a chain track element in respect to machine centerline. The position of this element is determined by the position of its two ends in respect to machine centerline. These positions in turn are given by the respective AP03s. The angle is calculated as follows:

- | | | |
|-----|---|---|
| a | = | $\arctan (PW2-PW1)/(d*2)$ |
| PW1 | = | position of AP03 at beginning of chain track element |
| PW2 | = | position of AP03 at end of chain track element |
| d | = | distance between beginning and end of chain track element |

The factor „2“ is because the position value contains angle information concerning both chain tracks. More positive angle is defined as an angle being formed when space between chain tracks becomes greater looking towards the exit of the machine.

Since each AP03 calculates the leading and also the lagging angles to the adjacent chain track elements, the following parameters are necessary:

- | | |
|----|--------------------------------|
| A+ | upper angle to lagging spindle |
| A- | lower angle to lagging spindle |
| B+ | upper angle to leading spindle |
| B- | lower angle to leading spindle |
| d1 | zone length to lagging spindle |
| d2 | zone length to leading spindle |

The following sketch shows the different angles and zone length for a any spindle „n“. The abbreviations have the following meaning:

- | | | |
|------|---|--|
| PW´ | = | position of lagging spindle |
| PW | = | position of spindle „n“ |
| PW´´ | = | position of leading spindle |
| a | = | actual angle of chain track element to lagging spindle |
| b | = | actual angle of chain track element to leading spindle |
| a | = | b´ |
| b | = | a´´ |

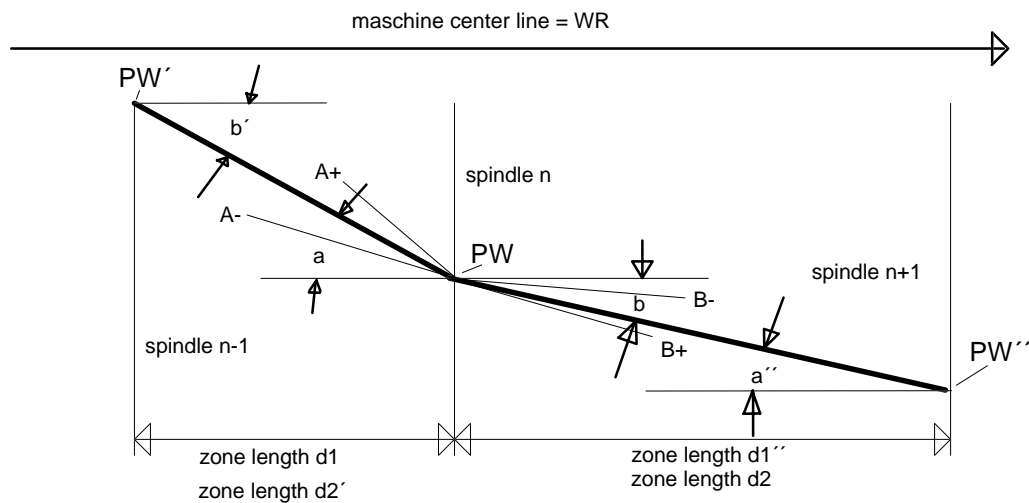

Looking at this sketch the following relationships regarding zone length, can be seen:

Zone length „d1“ of spindle „n“ is identical to zone length „d2“ of spindle „n-1“ etc.

The same is true for the actual angle and the angle-limits:

The angles „b“, „B-“, „B+“ of spindle „n“ to the following spindle „n-1“ are identical to the angles „a“, „A-“, „A+“ of spindle „n+1“.

MX08/2 Commands :

Hex	abbr.	size	access	description
00H	Reset	K/K W	W	MX08/2 is reseted. All important parameters and datas are set to default values.
01H	UAA	K/L W	W	writes out the number of substations. The 1st data byte shows the overall numbers of substations, the 2nd databyte shows the substations equipped with actuators
02H	ASMA	K/L W	W	writes out the actual recipe number
03H	ASMU	L/L W	W	reads in the actual recipe number
04H	AGAA	K/L W	W	writes out the actual device address
05H	AGAU	L/L W	W	reads in the actual device address
06H	MODA	K/L W	W	write out the actual mode of operation
10H	SWA	K/L W	W	write out the actual value for actual recipe and actual device
1BH	GKA	K/L W	W	write out device address
20H	SWU	L/L W	W	read in the actual value for actual recipe and actual device.
32H	PREIN	K/K W	W	programming mode on
33H	PRAUS	K/K W	W	programming mode off
34H	TEIX	K/K W	W	keyboard on
35H	TAUS	K/K W	W	keyboard off
34H	SSA	K/K W	W	write out recipe status, 0 = actual values = recipe values 1 = actual values = recipe values
3CH	START	K/K W	W	start recipe positioning; recipe status will be deleted.
3dH	STOP	K/K W	W	stop recipe positioning

MX08/2 ERROR codes :

Hex	size	description
82H	K	data transmission error (CRC-/BLOCK-check error)
83H	K	improper or unknown command
85H	K	improper value input
8FH	K	data transmission error from substation to MX08/2
8FH	K	MX08/2 is not in controller mode of operation.

Additional AP03 commandes :

Hex	abbr.	size	access	description
00H	Reset	K/K	W w	MX08/2 is reseted. All important parameters and datas are set to default values.
A0H	A+AUS	K/L	W	write out A+ angle limit
A1H	A-AUS	K/L	W w	write out A- angle limit
A2H	B+AUS	K/L	W w	write out B+ angle limit
A3H	B-AUS	K/L	W w	write out B- angle limit
A4H	ALSA	K/L	W w	write out number of spindles in LS-groupe
A6H	D1AUS	K/L	W w	write out zone length d1
A7H	D2AUS	K/L	W w	write out zone length d2
B0H	A+EIN	L/L	W w	read in A+ angle limit
B1H	A-EIN	L/L	W w	read in A- angle limit
B2H	B+EIN	L/L	W w	read in B+ angle limit
B3H	B-EIN	L/L	W w	read in B- angle limit
B4H	ALSU	L/L	W w	read in number of spindles in LS-groupe
B6H	D1EIN	L/L	W w	read in zone length d1
B7H	D2EIN	L/L	W w	read in zone length d2
B8H	PSPER	K/K	W w	positioning locked
B9H	PFREI	K/K	W w	positioning unlocked

AP03 commands no longer in use :

Hex	description
19H	write out offset value
29H	read in offset value
43H	star button functions chain dimensioning no longer available.

MX08/2 Mode of Operation codes :

0	init system	mode of operation after power on
1	init display	initializing the display
2	system test	self check routine of MX08/2
3	scan-SIKONETZ	scanning sub stations
4	controller	top menue lever, converter mode
5	config. device	parameter choices for device to be configured
6	config. command	parameter choices for commands of chosen device
7	config. edit value	edit commands of chosen device
8	positioning	axis positioning is running
10	set value input	input of set values for axis positioning
11	select recipe	selection of set for recipe positioning
12	set act value	display of set- and act values of selected recipe.
13	write out set value	hand-over set value for the selected recipe
14	delete system status	deletes system status information of all substations.
15	start recipe position	starts recipe positioning
16	checks recipe position	checks system status of all substations during positioning

21	recipe programm 1	input of recipe value
22	recipe programm 2	input of recipe name
30	MX display	multiplex display for up to 3 position values.
40	select recipe input	select set value input, edit or teach-in
50	select plant params	selection of plant parameters
51	input axis	input of parameter „number o. axis“
52	input LS-groupe	input of parameter „number in LS“
53	select zone length	select parameter „zone length“
54	select angle input	select input for „angle limit“
55	input zone length	input parameter „zone length“
56	input angle limits	input parameter „angle limit“
57	initializing plant	initialize whole plant by writing out plant parameters to all AP03s.

Electrical connection of AP03 :

AP03 is connected via terminal box. Terminals are assigned as follows :

terminal	signal	signal description
1	GND device	device power supply - , GND
2	Ub device	device power supply +24 Vdc 120 mA
3	A3+	actuator 3 + active in rapid motion
4	A3-	actuator 3 -
5	A2+	actuator 2 + active in positioning ccw
6	A2-	actuator 2 -
7	A1+	actuator 1 + active in positioning cw
8	A1-	actuator 1 -
9	GND interface	interface power supply - ; GND do not overload !!!
10	DÜA	incoming bussignal A
11	DÜB	incoming bussignal B
12	N.C.	not connected
13	N.C.	not connected
14	GND interface	interface power supply - ; GND do not overload !!!
15	DÜA	out going bussignal A
16	DÜB	out going bussignal B
17	N.C.	not connected
18	N.C.	not connected
19	+5V	interface power supply +5Vdc ; output do not overload !!!
20	GND interface	interface power supply - ; GND do not overload !!!
21	Us	interface power supply + 12 ... 24Vdc, 50 mA

The whole interface, device power supply and the 3 actuators are separated galvanically. The actuators may be considered as being „open collector“ or „open emitter“ type outputs. In general it is possible to feed actuators, the interface and the whole device from one power supply, but it is not recommended, because of possible EM interferences. The terminals 9, 14 and 20 are shorted internally, same as terminals 10 and 15 as well as 11 and 16. The incoming busline is connected to 9, 10, and 11 while the out going line is connected to 14, 15 and 16. Terminal 19 should only be used to terminate the busline to fix signal levels.

Electrical connection of MX08/2:

MX08/2 has three pluggable terminal strips. Terminals are assigned as follows :

3-terminal	
PE	power GND
L	device power supply 230Vac
N	device power supply 230Vac

terminal	signal	signal description
lower terminal strip		
1	input key-switch	switching of access rights
2	input key-switch (ground)	
3 - 6	N.C.	
7 - 8	N.C.	
9 + 10	special output #2	active at width-limit-violation
11 -12	special output #1	active at angle-limit-violation
13	power GND	PE
upper terminal strip		
14	interface #1 GND	connection of PLC or PC-interface possible, use RS232 or RS422 type
15	TXDA RS422 interface #1	
16	TXDB RS422 interface #1	
17	RXDA RS422 / TX RS232 interface #1	
18	RXDB RS422 / RX RS232 interface #1	internally connected to term 14
19	interface #1 GND	
20	interface #2 GND	
21+22	N.C.	
23	DÜA RS485 interface #2	SIKONETZ-interface RS485
24	DÜB RS485 interface #2	
25	interface #2 GND	internally connected to term 20
26	power GND	PE

PLANT PARAMETERS :			
No.	DISCRIPTION	Range	Value
1	no. of spindles	0 ... 25	
2	Line-Shafting	0 ... 25	
3	zone length	0 ... 999999	
	zone length 1 - 2		zone length 2 - 3
	zone length 3 - 4		zone length 4 - 5
	zone length 5 - 6		zone length 6 - 7
	zone length 7 - 8		zone length 8 - 9
	zone length 9 - 10		zone length 10 - 11
	zone length 11 - 12		zone length 12 - 13
	zone length 13 - 14		zone length 14 - 15
	zone length 15 - 16		zone length 16 - 17
	zone length 17 - 18		zone length 18 - 19
	zone length 19 - 20		zone length 20 - 21
	zone length 21 - 22		zone length 22 - 23
	zone length 23 - 24		zone length 24 - 25
4	angle limits	- 45° ... +45°	
	upper limit 1		lower limit 1
	upper limit 2		lower limit 2
	upper limit 3		lower limit 3
	upper limit 4		lower limit 4
	upper limit 5		lower limit 5
	upper limit 6		lower limit 6
	upper limit 7		lower limit 7
	upper limit 8		lower limit 8
	upper limit 9		lower limit 9
	upper limit 10		lower limit 10
	upper limit 11		lower limit 11
	upper limit 12		lower limit 12
	upper limit 13		lower limit 13
	upper limit 14		lower limit 14
	upper limit 15		lower limit 15
	upper limit 16		lower limit 16
	upper limit 17		lower limit 17
	upper limit 18		lower limit 18
	upper limit 19		lower limit 19
	upper limit 20		lower limit 20
	upper limit 21		lower limit 21
	upper limit 22		lower limit 22
	upper limit 23		lower limit 23
	upper limit 24		lower limit 24
5	initialization		

Parameter setting :			MX08/2-S03
No.	Discription	Range	Setting
1	Language	German., Engl., French	
2	Protocol	Standard, FB	
3	Baudrate	300, 600, ... , 19200	
4	Viewing angle	-4 ... +3	
5	Recipe processing	none locked unlocked	
6	Axis positioning	none locked unlocked	

Parameter settings :		AP03	
Device adresse :			
No.	Description	Range	Setting
1	Counts / rev.	0 ... 65535	
2	Count divider	1 , 10 , 100 , 1000	
3	Count direction	I or E	
4	DP position	0 ... 4	
5	Calibration value	0 ... 999999	
6	Set calibration		
7	Turn around positioning	0 ... 65535	
8	Loop positioning	NONE , I , E	
9	Limit evaluation	OFF , ON	
10	Maximum width	0 ... 999999	
11	Minimum width	0 ... 999999	
12	Blocking monitoring	OFF , ON	
13	Blocking time	0 ... 327.68	
14	Blocking tolerance	0 ... 65535	
15	Keyboard	OFF , ON	
16	Starbutton	OFF , ACTIVE	
17	Display	OFF , ON , ADDRESS	
18	Actuators on	0 ... 7	
19	Device name	A ... z , 0 ... 9 max. 8 fig.	
20	Angle A+	- 45° ... +45°	
21	Angle A-	- 45° ... +45°	
22	Angle B+	- 45° ... +45°	
23	Angle B-	- 45° ... +45°	
24	Lagging length 1	0 ... 999999	
25	Lagging length 2	0 ... 999999	
26	Number of axes in LS	0 ... 25	

Additional information on system status of AP03 display

The 3 system status bytes include the following information:

Byte no.	Bit no.	Designation	State
1	0	Actuator 1	d
	1	Actuator 2	d
	2	Actuator 3	d
	3	Position value frozen	d
	4	Keyboard switched on	d
	5	Program mode on	d
	6	Limiting value compare (width) on	d
	7	Blocking control on	d
2	8	Error 01 displayed	s
	9	Error 02 displayed	s
	10	Error 03 displayed	s
	11	Error 05 displayed	s
	12	Angle violation monitoring; spindle blocked for positive movement	d
	13	Angle violation monitoring; spindle blocked for negative movement	d
	14	'0'	
	15	Axis was blocked.	s
3	16	Set value reached	s
	17	Switch point reached	s
	18	'0'	
	19	'0'	
	20	Lower limit value reached	s
	21	Upper limit value reached	s
	22	'0'	
	23	Axis positioning	d

Use command „SSA“ (3AH) to read out system status. Bit information marked with „d“ (dynamic) are automatically set/reset according to the information received. Bit information marked with 's' (static) always have to be reset to the present status via command „SSL“ (delete system state 3BH). To get a complete and updated status information, system status should be deleted prior to positioning. In system status each angle violation (axis blocking) of any of the spindles can be seen from bit 12 and bit 13 (bit 4 and bit 5 of the middle byte).

C. Appendix C

Angle- and Width-Violation-Monitoring System for Dornier TDO Streching Machines

for Softwareversion 2.0 of MX08/2 and AP03 schwarz LD 24.12.1994
frö SIKO 5.12.1994
frö SIKO 23.1.1995
frö SIKO 7.3.1995
frö SIKO 8.11.1995

General scope

It is the task of the angle- and width-violation-monitoring system to position (setting up desired stretching ratios) and monitor chain track elements. This is done by controlling the different spindles within a Dornier TDO stretching installation. The following SIKONETZ-components are used, to accomplish this task:

- 1*MX08/2 - central command station and leading part of SIKONETZ II fieldbus
- n*AP03 - absolute position indicator with integrated angle decoders, manual control elements, display and actuator outputs.
n = number of spindles to be monitored and controlled.

The system is capable of controlling 24 spindles at nearly the same time. Positioning can be done in 7 different ways.

1. stepping operation of a single spindle at its own AP03
2. stepping operation of a single spindle at MX08/2.
3. axis-positioning via setting-up desired set-value at its own AP03.
4. axis-positioning via setting-up desired set-value at MX08/2
5. recipe-positioning of all spindles at MX08/2.
6. axis-positioning of single axis via PLC or host computer
7. recipe-positioning of all spindles via PLC or host computer.

In addition the system has to be able to monitor each spindle individually. In case of violating a width- or an angle-limit, movement of the respective spindle has to be stopped and an error is to be given out. This error message is a readable text on the MX08/2 display, together with 2 potentialfree relais outputs at the MX08/2. An optional function is the so called „Line-Shafting“ (LS). It is a mechanical coupling of m adjacent spindles at machine inlet. This constallation has to be taken into consideration when monitoring angle violations. All system components are coupled together via SIKONETZ II fieldbus. The interface is a RS 485 type. Baudrate is 115.2 kBaud. The SIKONETZ II is operated in a master-slave configuration. The MX08/2 allways acts as master. For detailed information see SIKONETZ manual or SIKONETZ compendium.

Angle-violation monitoring :

The angles, formed by chain track elements and machine center line, have to be within certain limits. Values for these angles can be set up individually in parameter „angle c_{max} “ and „angle c_{min} “. Maximum angle, to be viewed in direction of the goods, is $+45^\circ$ and min. is -45° (in 1° steps). Angle evaluation (angle violation monitoring) is done by comparing the calculated „arcustangens“ values with listed limit-values. To do proper calculation, the positions of the adjacent spindles limiting the chain track element, as well as the distance (zone length) between respective spindles is necessary (see also chapter 'Definition of angle limit'). Since positioning and angle-limit monitoring takes place at each spindle, each AP03 does not only require the own position value but also the values of the adjacent spindles. Blockage of a certain spindle movement at the AP03 is indicated at the respective AP03 display. Depending on which direction is blocked, the upper or lower segment of the 7th display digit comes on. In case of optional LS, angle-limit monitoring is extended (see description „Line Shafting“). No monitoring takes place when either parameter „zone length“ or „angle limit“ (c_{max} and c_{min}) is set to „0“.

Width-violation monitoring :

Width-violation monitoring takes place at each AP03 permanently. The two width limit values are stored nonvolatily in the respective AP03. If, during motion, spindle position has reached one of the set limit values, the decimal point of 6th display digit comes on. In addition width-status in the MX08/2 display changes from „0“ to a certain number. This number shows the highest address of AP03, where width-limit-violation occurred.

Order of operation :

After power application MX08/2 scans the SIKONETZ. If all sub-stations (slaves) reply, the MX08/2 switches to converter mode. In this mode of operation, MX08/2 reads position values and status information of each AP03 permanently. So each AP03 receives the position values, necessary for angle calculations, from its adjacent spindles by simply listening to the bus. This mode also allows direct spindle positioning from MX08/2. By choosing the respective menue, axis-, as well as recipe-positioning is possible. If axis- or recipe-positioning has been chosen at MX08/2, individual positioning at AP03 is omitted. In submenu „axispositioning“, a single axis can be positioned with active width- and angle-limit evaluation.

Line Shafting (LS) :

The spindles in the inlet section of the TDO are coupled together in a groupe mechanically. This coupling is called „Line-Shafting“ (LS). Driving the first spindle subsequently moves all elements within the LS-groupe, although each element has an overriding positioning drive on its own. The first spindle has address 01. The number of spindles within LS-groupe (size of groupe) is given by parameter „Line Shafting“. When a LS-groupe is defined, a few special features are activated during recipe-positioning and angle-limit evaluation. A LS-groupe definition is valid when parameter „Line Shafting“ is no longer „0“. In case of recipe-positioning only spindle address „1“ is moved electrically. The drive motors of the remaining spindles within LS-groupe will not be used. The angle-limit evaluation of address“1“ is extended during LS-group positioning. Since spindle 1 drive moves the whole LS-groupe, AP03, address „1“, has to consider the angle formed between the last element of the LS-groupe. Whenever angle-violation occurs, anywhere within LS-groupe, AP03 address „1“ ist stopped. In addition this locking is indicated in MX08/2's display.

Setting addresses :

For proper operation of SIKONETZ II device addresses have to be assigned in a certain order. In general addresses can range from „0“ to „31“. Address „0“ ist definitely reserved for the master controller MX08/2. All axis to be monitored will be given an address, starting with „1“ and continuing gapless to the last one. Address „1“ belongs to the first spindle at TDO's inlet. All following AP03s will be assigned an address in accordance to its appearance within the mechanical order of the whole machine.

Setting-up a new installation :

Set-up of a new installation should be done in a certain manner.

- check all involved wiring
- set device addresses
- switch on device power supply
- switch on interface power supply
- switch on actuator power supply
- set-up AP03 parameters according to parameter sheets

- set-up MX08/2 parameters according to parameter sheets
- set-up plant parameters according to parameter sheets
- calibrate all AP03s
- check ability to position axis, single or in a recipe
- check ability to evaluate angle- and/or width-limit-violation
- if asked for, couple MX08/2 to PLC or any host computer via RS422.

Calibration :

Calibration means, to adapt the display reading of an absolute angle encoder, like the AP03, to its actual mechanical position. Before calibration the count direction (cw or ccw) must be checked, and changed, if necessary. Next the mechanical position of each AP03 has to be found out. Use a steel measuring band to determine the precise distance between the two respective clip tables. This value is to be given into the respective AP03 as calibration value. This programming can be done at the MX08/2 directly, from the PLC, or from a host computer via interface RS422, if connected. Next, the specific calibration is to be carried out for each AP03 by choosing menu line „calibrate“ (zeroing = set starting position) in menu „device parameter“. Pressing „input“ key, the before programmed position value is taken over by the respective AP03. Calibration can also be achieved by mechanically turn the internal AP03 gears via screwdriver.

Initializing the plant from MX08/2 :

Since it is rather time consuming and therefore sensitive for mistakes, programming a bigger installation with up to 24 spindles locally from each AP03, a new menu, „plant parameters“, was initiated, to enable the operator to do programming of all device parameters within the whole installation from MX08/2 and then send it out to the AP03s via SIKONETZ fieldbus. This menu line is located in the top menu (converter-, controller-mode). After selection the following 5 submenus appear:

- No. of Spindles - amount of axis/AP03 to be handled
- Line Shafting - amount of axis/AP03 is LS-group
- Zone length - distances between adjacent spindles
- Angle limit - angle limits $c_{max.}$ and $c_{min.}$
- Initialization - hand over the parameters to the respective device.

This kind of parameter setting lets the operator handle less parameters. This is pointed out by the following example:

Zone length „d1“ of AP03, address „7“ is identical to „d2“ of AP03, address „6“ and therefore has to be programmed only once.

Display and operating elements of AP03 :

In addition to the actual position values the AP03 display indicates status informations. A width violation is indicated by the decimal point of the 6th display digit. When axis positioning is running the decimal point, set with parameter setting „dp position“, flashes. When angle-limit violation occurs, the top or bottom element of 7th display digit comes on, whichever is true.

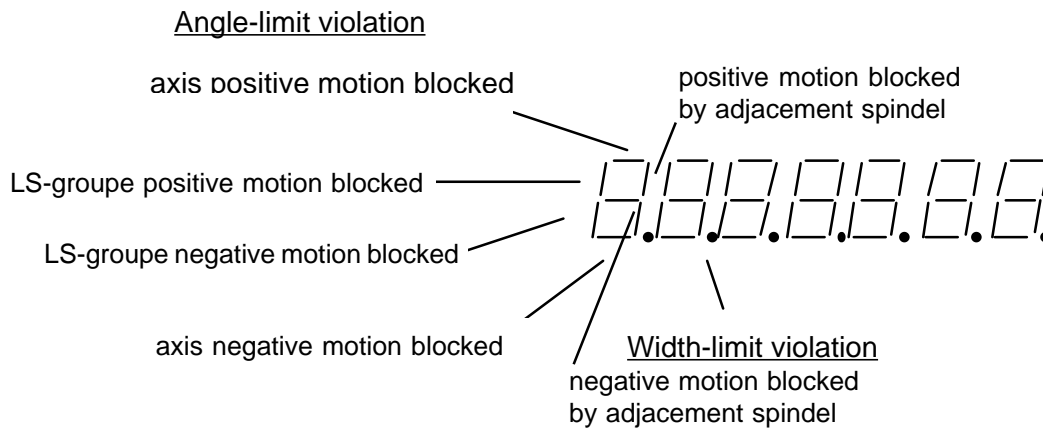

The three key buttons on each AP03 may be used to position the respective spindle (axis) manually. In stepping mode, one of the arc-buttons together with the star-button have to be pressed to move the respective spindle. To give in a new set-value, simply push both arc-buttons together. Next the set value may be changed by first choosing the decade to be changed with the right arc-button and than change numbers by using the left arc-button. The positioning is started by pushing the star-button.

Coupling the whole plant to PLC/PC computer via interface :

Merely all actions of the MX08/2 may be initiated by an external device using an interface. To get proper performances some definitions have to be agreed and kept. Interfaces to PLC/PC can be a RS232 or a RS422 type. Both use no hardware handshake. In device parameters for MX08/2 one of the two protocols can be chosen: „standard“ or „FB“. Standard uses 8 databits and no parity. Two checkbytes are added to each telegram. A CRC routine generates these two checkbytes. For the „FB“ protocol however the telegram consists of 8 databits and 1 even-parity bit. For this protocol the check information is a block-check-byte. It is generated by an EXOR combination of all bytes of a transmitted telegram. Baudrate can be varied by a device parameter between 300 and 19200 Baud. Since we have a binary transmissions, the telegram is synchronized by time synchronsation. See MX08/2-manual or SIKONETZ-compendium for more information about protocols and command structure.

Axis positioning via interface :

A command structure for positioning an axis might look as follows:

Each line stands for a telegram to be sent to an AP03. Addresses and commands for the specific AP03 have to be added to the lines to reach a certain AP03.

1. SWU send set value
2. SSL clear status, all error messages and statistic infos will be deleted.
3. START start positioning
4. SSA read out system status
5. repeat line 4 until actual value meets set value or until error occurs.

Recipe positioning via interface :

A command structure for positioning a recipe might look as follows:

Each line stands for a telegram to be sent to the MX08/2. Address and commands for MX08/2 have to be added to the lines.

1. PREIN switch MX08/2 to programming mode
2. ASNU hand over number of actual recipe (e.g. „5“ for recipe 5)
3. PRAUS switch off programming mode
4. START start actual recipe
5. SSA read out state of actual recipe
6. MODA read out MX08/2's actual mode of operation.
7. Repeat from line 5 until actual value meets recipe value or until error occurs. For safety reasons, the recipe positioning is canceled when an error occurred. If recipe positioning has been started from the keyboard, an error message will be displayed. If recipe message occurs during recipe positioning via interface, MX08/2 changes mode of operation to controller mode.

Definition of angle evaluation :

The angle to be evaluated is per definition the angle of two successive chain tracks in respect to machine centerline (see sketch). The position (angle) of these elements is determined by the position of each chain track ends. These positions in turn are given by the respective AP03s. The angle is deduced from the two chain track angles in respect to machine centerline and calculated as follows:

$$c = b - a$$

Angles a and b can be calculated as follows:

$$a = \arctan ((PW - PW_{n-1}) / d1/2)$$

$$b = \arctan ((PW_{n+1} - PW) / d2/2)$$

Since arctangus calculation entails time problems, angle/width monitoring is made according to the following approximate calculation:

$$\tan c = \tan b - \tan a$$

- PW = AP03 reading for spindle 'n'
 PW_{n-1} = AP03 reading for lagging spindle
 PW_{n+1} = AP03 reading for leading spindle
 d1 = distance (zone length) to lagging spindle
 d2 = distance (zone length) to leading spindle

The factor „2“ is because the position value contains angle information concerning both chain tracks. More positive angle is defined as an angle being formed when space between chain tracks becomes greater looking towards the exit of the machine.

Since each AP03 calculates the leading and also the lagging angles to the adjacent chain track elements, the following parameters are necessary:

- c_{max.} maximum angle limit (chain track facing away from center line)
 c_{min.} maximum angle limit (chain track facing towards center line)
 d1 zone length to lagging spindle
 d2 zone length to leading spindle

The following sketch shows the different angles and zone lengths for any spindle „n“. The abbreviations have the following meaning:

- PW = position of spindle „n“
 PW_{n-1} = position of lagging spindle
 PW_{n+1} = position of leading spindle
 a = actual angle of lagging chain track element to machine center line
 b = actual angle of leading chain track element to machine center line
 c = angle limit of spindle „n“

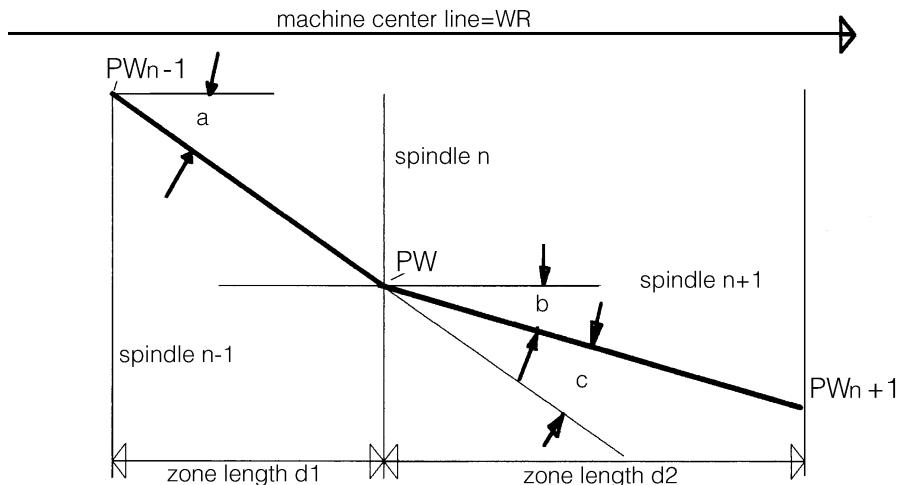

Looking at this sketch the following relationships regarding zone length, can be seen:

Zone length „d1“ of spindle „n“ is identical to zone length „d2“ of spindle „n-1“ etc.

MX08/2 Commands :

Hex	abbr.	size	access	description
00H	Reset	s/s	w	MX08/2 is reseted. All important parameters and datas are set to default values.
01H	UAA	s/l	w	writes out the number of substations. The 1st data byte shows the overall numbers of substations, the 2nd databyte shows the substations equipped with actuators
02H	ASMA	s/l	w	writes out the actual recipe number
03H	ASMU	l/l	w	reads in the actual recipe number
04H	AGAA	s/l	w	writes out the actual device address
05H	AGAU	l/l	w	reads in the actual device address
06H	MODA	s/l	w	write out the actual mode of operation
10H	SWA	s/l	w	write out the actual value for actual recipe and actual device
1BH	GKA	s/l	w	write out device address
20H	SWU	l/l	w	read in the actual value for actual recipe and actual device.
32H	PREIN	s/s	w	programming mode on
33H	PRAUS	s/s	w	programming mode off
34H	TEIN	s/s	w	keyboard on
35H	TAUS	s/s	w	keyboard off
3AH	SSA	s/l	w	write out recipe status, 0 = actual values = recipe values not reached 1 = actual values = recipe values reached
3CH	START	s/s	w	start recipe positioning; recipe status will be deleted.
3dH	STOP	s/s	w	stop recipe positioning

MX08/2 ERROR codes :

Hex	size	description
82H	s	data transmission error (CRC-/BLOCK-check error)
83H	s	improper or unknown command
85H	s	improper value input
8FH	s	data transmission error from substation to MX08/2
8FH	s	MX08/2 is not in controller mode of operation.

Additional AP03 commandes :

Hex	abbr.	size	access	description
00H	Reset	s/s	w	MX08/2 is reseted. All important parameters and datas are set to default values.
A0H	C+AUS	s/l	w	write out angle limit ($C_{max.}$)
A1H	C-AUS	s/l	w	write out angle limit ($C_{min.}$)
A4H	ALSA	s/l	w	write out number of spindles in LS-groupe
A6H	D1AUS	s/l	w	write out zone length d1
A7H	D2AUS	s/l	w	write out zone length d2
B0H	C+EIN	l/l	w	read in angle limit ($C_{max.}$)
B1H	C-EIN	l/l	w	read in angle limit ($C_{min.}$)
B4H	ALSU	l/l	w	read in number of spindles in LS-groupe
B6H	D1EIN	l/l	w	read in zone length d1
B7H	D2EIN	l/l	w	read in zone length d2
B8H	PSPER	s/s	w	positioning locked
B9H	PFREI	s/s	w	positioning unlocked

AP03 commands no longer in use :

Hex	description
19H	write out offset value
29H	read in offset value
43H	star button functions chain dimensioning no longer available.

MX08/2 Mode of Operation codes :

0	init system	mode of operation after power on
1	init display	initializing the display
2	system test	self check routine of MX08/2
3	scan-SIKONETZ	scanning sub stations
4	controller	top menue lever, converter mode
5	config. device	parameter choices for device to be configured
6	config. command	parameter choices for commands of chosen device
7	config. edit value	edit commands of chosen device
8	positioning	axis positioning is running
10	set value input	input of set values for axis positioning
11	select recipe	selection of set for recipe positioning
12	set act value	display of set- and act values of selected recipe.
13	write out set value	hand-over set value for the selected recipe
14	delete system status	deletes system status information of all substations.
15	start recipe position	starts recipe positioning
16	checks recipe position	checks system status of all substations during positioning

21	recipe programm 1	input of recipe value
22	recipe programm 2	input of recipe name
30	MX display	multiplex display for up to 3 position values.
40	select recipe input	select set value input, edit or teach-in
50	select plant params	selection of plant parameters
51	input axis	input of parameter „number o. axis“
52	input LS-groupe	input of parameter „number in LS“
53	select zone length	select parameter „zone length“
54	select angle input	select input for „angle limit“
55	input zone length	input parameter „zone length“
56	input angle limits	input parameter „angle limit“
57	initializing plant	initialize whole plant by writing out plant parameters to all AP03s.

Electrical connection of AP03 :

AP03 is connected via terminal box. Terminals are assigned as follows :

terminal	signal	signal description
1	GND device	device power supply - , GND
2	Ub device	device power supply +24 Vdc 120 mA
3	A3+	actuator 3 + active in rapid motion
4	A3-	actuator 3 -
5	A2+	actuator 2 + active in positioning ccw
6	A2-	actuator 2 -
7	A1+	actuator 1 + active in positioning cw
8	A1-	actuator 1 -
9	GND interface	interface power supply - ; GND do not overload !!!
10	DÜA	incoming bussignal A
11	DÜB	incoming bussignal B
12	N.C.	not connected
13	N.C.	not connected
14	GND interface	interface power supply - ; GND do not overload !!!
15	DÜA	out going bussignal A
16	DÜB	out going bussignal B
17	N.C.	not connected
18	N.C.	not connected
19	+5V	interface power supply +5Vdc ; output do not overload !!!
20	GND interface	interface power supply - ; GND do not overload !!!
21	Us	interface power supply + 12 ... 24Vdc, 50 mA

The whole interface, device power supply and the 3 actuators are separated galvanically. The actuators may be considered as being „open collector“ or „open emitter“ type outputs. In general it is possible to feed actuators, the interface and the whole device from one power supply, but it is not recommended, because of possible EM interferences. The terminals 9, 14 and 20 are shorted internally, same as terminals 10 and 15 as well as 11 and 16. The incoming busline is connected to 9, 10, and 11 while the out going line is connected to 14, 15 and 16. Bus termination is accomplished via solder points on the PCB of the last ap03's terminal box.

Electrical connection of MX08/2:

MX08/2 has three pluggable terminal strips. Terminals are assigned as follows :

3-terminal	
PE	power GND
L	device power supply 230Vac
N	device power supply 230Vac

terminal	signal	signal description
lower terminal strip		
1	input key-switch	switching of access rights
2	input key-switch (ground)	
3 - 6	N.C.	
7 - 8	N.C.	
9 + 10	special output #2	active at width-limit-violation
11 -12	special output #1	active at angle-limit-violation
13	power GND	PE
upper terminal strip		
14	interface #1 GND	connection of PLC or PC-interface possible, use RS232 or RS422 type
15	TXDA RS422 interface #1	
16	TXDB RS422 interface #1	
17	RXDA RS422 / TX RS232 interface #1	
18	RXDB RS422 / RX RS232 interface #1	
19	interface #1 GND	internally connected to term 14
20	interface #2 GND	
21+22	N.C.	
23	DÜA RS485	SIKONETZ-interface RS485
24	DÜB RS485	
25	interface #2 GND	internally connected to term 20
26	power GND	PE



PLANT PARAMETERS :			
No.	DISCRIPTION	Range	Value
1	no. of spindles	0 ... 25	
2	Line-Shafting	0 ... 25	
3	zone length	0 ... 999999	
	zone length 1 - 2		zone length 2 - 3
	zone length 3 - 4		zone length 4 - 5
	zone length 5 - 6		zone length 6 - 7
	zone length 7 - 8		zone length 8 - 9
	zone length 9 - 10		zone length 10 - 11
	zone length 11 - 12		zone length 12 - 13
	zone length 13 - 14		zone length 14 - 15
	zone length 15 - 16		zone length 16 - 17
	zone length 17 - 18		zone length 18 - 19
	zone length 19 - 20		zone length 20 - 21
	zone length 21 - 22		zone length 22 - 23
	zone length 23 - 24		zone length 24 - 25
4	max. angle limits	- 45° ... +45°	
	C_{max.}		C_{min.}
	upper limit 1		lower limit 1
	upper limit 2		lower limit 2
	upper limit 3		lower limit 3
	upper limit 4		lower limit 4
	upper limit 5		lower limit 5
	upper limit 6		lower limit 6
	upper limit 7		lower limit 7
	upper limit 8		lower limit 8
	upper limit 9		lower limit 9
	upper limit 10		lower limit 10
	upper limit 11		lower limit 11
	upper limit 12		lower limit 12
	upper limit 13		lower limit 13
	upper limit 14		lower limit 14
	upper limit 15		lower limit 15
	upper limit 16		lower limit 16
	upper limit 17		lower limit 17
	upper limit 18		lower limit 18
	upper limit 19		lower limit 19
	upper limit 20		lower limit 20
	upper limit 21		lower limit 21
	upper limit 22		lower limit 22
	upper limit 23		lower limit 23
	upper limit 24		lower limit 24
5	initialization		

Parameter setting :			MX08/2-S03
No.	Description	Range	Setting
1	Language	German., Engl., French	
2	Protocol	Standard, FB	
3	Baudrate	300, 600, ... , 19200	
4	Viewing angle	-4 ... +3	
5	Recipe processing	none locked unlocked	
6	Axis positioning	none locked unlocked	

Parameter settings :		AP03	
Device adresse :			
No.	Parameter	Range	Setting
1	Counts / rev.	0 ... 65535	
2	Count divider	1 , 10 , 100 , 1000	
3	Count direction	I or E	
4	DP position	0 ... 4	
5	Calibration value	0 ... 999999	
6	Zeroing		
7	Turn around positioning	0 ... 65535	
8	Loop positioning	NONE , I , E	
9	Limit evaluation	OFF , ON	
10	Maximum width	0 ... 999999	
11	Minimum width	0 ... 999999	
12	Blocking monitoring	OFF , ON	
13	Blocking time	0 ... 327.68	
14	Blocking tolerance	0 ... 65535	
15	Keyboard	OFF , ON	
16	Starbutton	OFF , ACTIVE	
17	Display	OFF , ON , ADDRESS	
18	Actuators on	0 ... 7	
19	Device name	A ... z , 0 ... 9 max. 8 fig.	
20	Angle C _{max.}	- 45° ... +45°	
21	Angle C _{min.}	- 45° ... +45°	
22	distance 1	0 ... 999999	
23	distance 2	0 ... 999999	
24	Number of axes in LS	0 ... 25	

Additional information on system status of AP03 display

The 3 system status bytes include the following information:

Byte no.	Bit no.	Designation	State
1	0	Actuator 1	d
	1	Actuator 2	d
	2	Actuator 3	d
	3	Position value frozen	d
	4	Keyboard on	d
	5	Program mode on	d
	6	Limiting value compare (width) on	d
	7	Blocking control on	d
2	8	Error 01 displayed	s
	9	Error 02 displayed	s
	10	Error 03 displayed	s
	11	Error 05 displayed	s
	12	Angle violation monitoring; positive movement blocked	d
	13	Angle violation monitoring; negative movement blocked	d
	14	'0'	
	15	Axis was blocked.	s
3	16	Set value reached	s
	17	Switch point reached	s
	18	'0'	
	19	'0'	
	20	Lower limit value reached	s
	21	Upper limit value reached	s
	22	'0'	
	23	Axis positioning	d

Use command „SSA“ (3AH) to read out system status. Bit information marked with „d“ (dynamic) are automatically set/reset according to the information received. Bit information marked with 's' (static) always have to be reset to the present status via command „SSL“ (delete system state 3BH). To get a complete and updated status information, system status should be deleted prior to positioning. In system status each angle violation (axis blocking) of any of the spindles can be seen from bit 12 and bit 13 (bit 4 and bit 5 of the middle byte).

